



jade 55

GYALOGKÍSÉRETŰ TAKARÍTÓGÉP

HASZNÁLATI ÉS KARBANTARTÁSI ÚTMUTATÓ

EN

**jade 50
jade 55
jade 66**

06 2020



Use and maintenance



Warning! Please read the instructions before use.

ADIATEK srl

**Head Office:
Via Monte Pastello, 14
I-37057 San Giovanni Lupatoto (VR)**

**Tel. +39 045 877 9086
Fax. +39 045 877 9195**

www.adiatek.com - info@adiatek.com

TECHNICAL DESCRIPTION	U/M	jade 50	jade 55	jade 66
Cleaning width	mm	500	550	660
	in	19,7	22	26
Squeegee width	mm	850	850	850
	in	34	34	34
Working capacity, up to	m ² /h	2250	2475	3000
	sqft/h	24,219	26,641	32,292
Brushes diameter	mm	1 x 508	2 x 285	2 x 345
	in	1 x 20	2 x 11	2 x 13
Brushes rpm	giri/min (rpm)	165	370	200
Pressure on the brushes	kg	36	32	50
	lbs.	79	71	110
Brushes motor	W	600	600	800
	A	25	25	33
Traction motor	W	180	180	180
	A	7.5	7.5	7.5
Suction motor	W	400	400	400
	A	16.7	16.7	16.7
Suction vacuum	mbar	120	120	120
	water lift	48	48	48
Type of drive		automatic	automatic	automatic
Movement speed	km/h	3,2 - 4,5	3,2 - 4,5	3,2 - 4,5
	mph	2-2.8	2-2.8	2-2.8
Maximum gradient	%	10	10	10
Solution tank	l	53	53	53
	gal	14	14	14
Recovery tank	l	56	56	56
	gal	15	15	15
Machine length	mm	1335	1272	1360
	in	52.6	50	54
Machine height	mm	1078	1078	1098
	in	42,4	42,4	43,2
Machine width (without squeegee)	mm	590	604	720
	in	23	24	28
Weight of the machine (empty and without batteries)	kg	101	100	111
	lbs.	222	221	225
Gross weight of the machine (in conformity with EN 60335-2-72 art. 5.z102)	kg	298	297	308
	lbs.	657	655	679
Capacity of the batteries	Ah ₅	180	180	180
Weight of the batteries	kg	144	144	144
	lbs.	318	318	318
Compartment of the batteries	mm	390x405x374	390x405x374	390x405x374
	in	15x16x15	15x16x15	15x16x15
Acoustic pressure level (in conformity with EN 60704-1) Lpa	dB (A)	68,5	68,1	68
Vibration to the system hand-arm	m/s ²	0,53	0,89	0,45
Class		III	III	III
Protection level	IP	X3	X3	X3
Tension	V	24	24	24

INTRODUCTORY COMMENT

Thank you for having chosen our machine. This floor cleaning machine is used for **commercial use**, for example **hotels, schools, hospitals, factories, shops, offices and rental business**. It is used for the industrial and civil cleaning and is able to clean any type of floor. During its advance movement, the combined action of the brush and the detergent solution removes the dirt which is aspirated through the rear suction assembly, giving a perfectly dry surface.

The machine must be used only for such purpose. It gives the best performance if it is used correctly and maintained in perfect efficiency. We therefore ask you to read this instruction booklet carefully whenever difficulties arise in the course of the machine's use.

In case of need, we ask you to contact our service department for all advice and servicing as may prove necessary.

ATTENTION: This machine is for internal use only.

ATTENTION: This machine must only be stored indoors.

SUMMARY

INTRODUCTORY COMMENT 3
 GENERAL RULES OF SAFETY 4
 Transfer 4
 Storage and disposal 4
 Correct use 4
 Maintenance 4
 GENERAL RULES OF THE BATTERIES 4
 LEGEND INSTRUMENT BOARD AND CONTROLS 5
 LEGEND MACHINE 5
 SYMBOLOGY ON THE MACHINE 6
 SYMBOLOGY ON THE MANUAL 6
 OPTIONAL ACCESSORIES 7

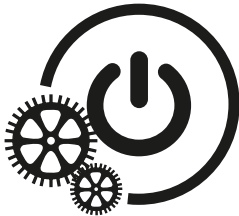

BEFORE USE 8
 Handling of the packed machine 8
 Unpacking of the machine 8
 Battery installation 8
 Battery recharger 9
 Incorporated battery recharger (optional) 9
 Batteries recharging 9
 Batteries recharging with on-board charger (optional) 9
 Batteries disposal 9
 Batteries charge level indicator 9
 Hour meter 10
 Squeegee assembly 10
 Adjustment of the squeegee 10
 Splash guard assembly 10
 Brushes assembly 11

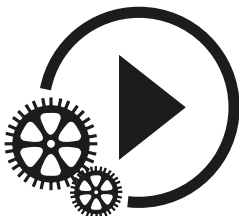

FLOOR CLEANING 12
 Connection of the batteries to the machine 12
 Recovery tank 12
 Detergent solution tank 12
 3S System "Solution Saving System" (optional) 12
 Selecting and working with ozone (optional) 13
 Starting of the machine 13
 Forward movement 13
 Speed adjustment 13
 Working brake 13
 Emergency brake 14
 Adjustment of the brushes pressure 14
 Brushes motor overload protection device 14
 Overflow device 14

Signal detergent solution reserve (H2O on the display) 14



STOP OF THE MACHINE AFTER CLEANING OPERATION 15
DAILY MAINTENANCE 15
 Recovery tank cleaning 15
 Suction filter cleaning 15
 Automatic disassembly of the brushes 15
 Manual disassembly of the brushes 15
 Brushes cleaning 16
 Squeegee cleaning 16
WEEKLY MAINTENANCE 16
 Rear squeegee rubber check 16
 Squeegee hose cleaning 16
 Squeegee "V" type (optional) 17
 Squeegee "V" type (optional): rear rubber check 17
 Cleaning of solution tank and filter 17
TWO-MONTHLY MAINTENANCE 17
 Front squeegee rubber check 17
 Squeegee "V" type (optional): front rubber check 18
SIX-MONTHLY MAINTENANCE 18
 Splash guard replacement 18
 Check of the brake 18
TROUBLESHOOTING GUIDE 19
 Signals on the display 19
 The suction motor does not work 19
 The brushes motor does not work 19
 The traction motor does not work 19
 Insufficient water on the brushes 20
 Machine does not clean properly 20
 The squeegee does not dry perfectly 20
 Excessive foam production 20
PROGRAMMED MAINTENANCE 21

GENERAL RULES OF SAFETY

The rules below have to be followed carefully in order to avoid injury to the operator and damage to the machine.

- Read the labels carefully on the machine. Do not cover them for any reason and replace them immediately if damaged.
- **ATTENTION:** The machine must be used exclusively by authorized staff.
- **ATTENTION:** Operators must be properly trained on the use of these machines.
- **ATTENTION:** The machine is not to be used by persons, children included, with reduced physical, sensorial or mental capabilities, or with lack of experience or knowledge.
- **ATTENTION:** Do not use the machine on areas having a higher gradient than the one stated on the machine.
- During the operation of the machine, pay attention to other people and especially to the children.
- Children must be supervised to ensure that they do not play with the appliance.
- Children cannot carry out cleaning and maintenance intended to be completed by the user.

TRANSFER

- Do not strike shelvings or scaffoldings where there is danger of falling objects.
- Leaving the machine in parking position, take off the key and act upon the parking brake.
- Do not use the machine as a means of transport.
- Adapt the working speed to the adhesion conditions: particularly, slow down before narrow curves have to be faced.

STORAGE AND DISPOSAL

- Storage temperature: between 0°C and +55°C (32°F e 131°F).
- Perfect operating temperature: between 0°C and +40°C (32°F e 104°F).
- The humidity should not exceed 95%.
- Provide for the scrapping of the material of normal wear following strictly the respective rules.

When your machine has to stop activity, provide for the appropriate waste disposal of its materials, especially oils, batteries and electronic components, and considering that the machine itself has been, where possible, constructed using recyclable materials.

CORRECT USE

- Do not use the machine on surfaces covered with inflammable liquids or dusts (for example hydrocarbons, ashes or soot).
- In case of fire, use a powder-based fire-extinguisher. Do not use water.
- Do not use the machine in explosive atmosphere.
- The machine has to carry out simultaneously the operations of washing and drying. Different operations must be carried out in restricted areas prohibited to non-authorized personnel and the operator has to wear suitable shoes.
- Signal the areas of moist floors with suitable signs.
- Do not mix different detergents, avoiding harmful odours.
- Avoid brushes operation when the machine is standing still in order to prevent floor damages.
- Before lifting the recovery tank, make sure that it is empty.

MAINTENANCE

- If the machine does not work properly, check by conducting simple maintenance procedures. Otherwise, as for technical advice from an authorized assistance centre.
- For any cleaning and/or maintenance operation take off the power supply from the machine.
- Where parts are required, ask for ORIGINAL spare parts from the distributor and/or from an authorized dealer.
- Use only ORIGINAL brushes.
- Do not take off the protections which require the use of tools for their removal.
- Do not wash the machine with direct water, jets or with high water pressure nor with corrosive material.

- Every 200 working hours have a machine check by an authorized service department.
- Before using the machine, check that all panels and coverings are in their position as indicated in this use and maintenance catalogue.
- Restore all electrical connections after any maintenance operation.

GENERAL RULES OF THE BATTERIES



- At any intervention on the batteries, use suitable acid-proof gloves and glasses.
- Do not smoke near the batteries and do not approach them with free flames.
- Check that a fire-extinguisher is available on site.
- Be very careful in case of leakages or liquid outlets because corrosive.
- Do not place any metallic tools onto the batteries. Risk of short circuit!
- It is compulsory to hand over exhaust batteries, classified as dangerous waste, to an authorized institution according to the current laws.

LEGEND INSTRUMENT BOARD AND CONTROLS

1. DISPLAY CHARGE LEVEL BATTERIES/HOUR METER
2. PUSH BUTTON VISUALIZATION HOUR METER (DISPLAY)
3. SIGNAL LAMP BRAKE ON
4. SWITCH SOLENOID VALVE/COMMUTATOR 3S SYSTEM (OPTIONAL)
5. SWITCH BRUSHES MOTOR
6. SWITCH SUCTION MOTOR
7. PUSH BUTTON BRUSH RELEASE
8. SWITCH WITH KEY
9. LEVERS DRIVE CONTROL
10. LEVER PARKING / EMERGENCY BRAKE
11. LEVER SOLUTION VALVE
12. LEVER SQUEEGEE LIFTING
13. PEDAL BRUSHES BASE GROUP LIFTING
14. SWITCH SPEED SELECTION

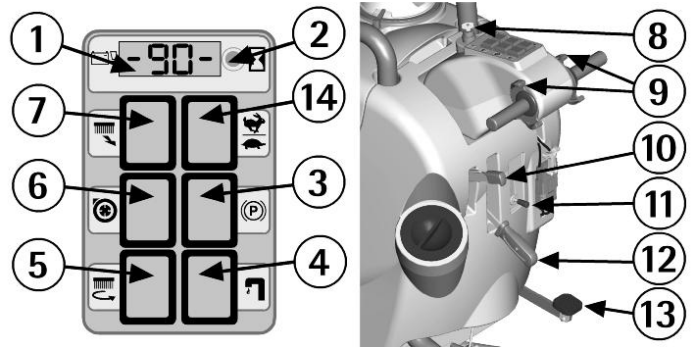

LEGEND MACHINE

1. CASTOR WHEELS
2. WHEELS
3. BRUSHES BASE GROUP
4. SOLUTION TANK
5. SCREW CAP FOR INLET DETERGENT SOLUTION
6. RECOVERY TANK
7. PLUG EXHAUST HOSE RECOVERY TANK
8. INLET OPENING SQUEEGEE HOSE
9. SUCTION COVER
10. SWITCH WITH KEY

11. INSTRUMENT BOARD
12. LEVERS DRIVE CONTROL
13. HANDLE BARS
14. LEVER PARKING / EMERGENCY BRAKE
15. CONNECTOR BATTERIES
16. LEVER SOLUTION VALVE
17. LEVER SQUEEGEE LIFTING
18. PEDAL BRUSHES BASE GROUP LIFTING
19. SQUEEGEE HOSE
20. SQUEEGEE ASSEMBLY
21. GUIDE SPRING SQUEEGEE HOSE

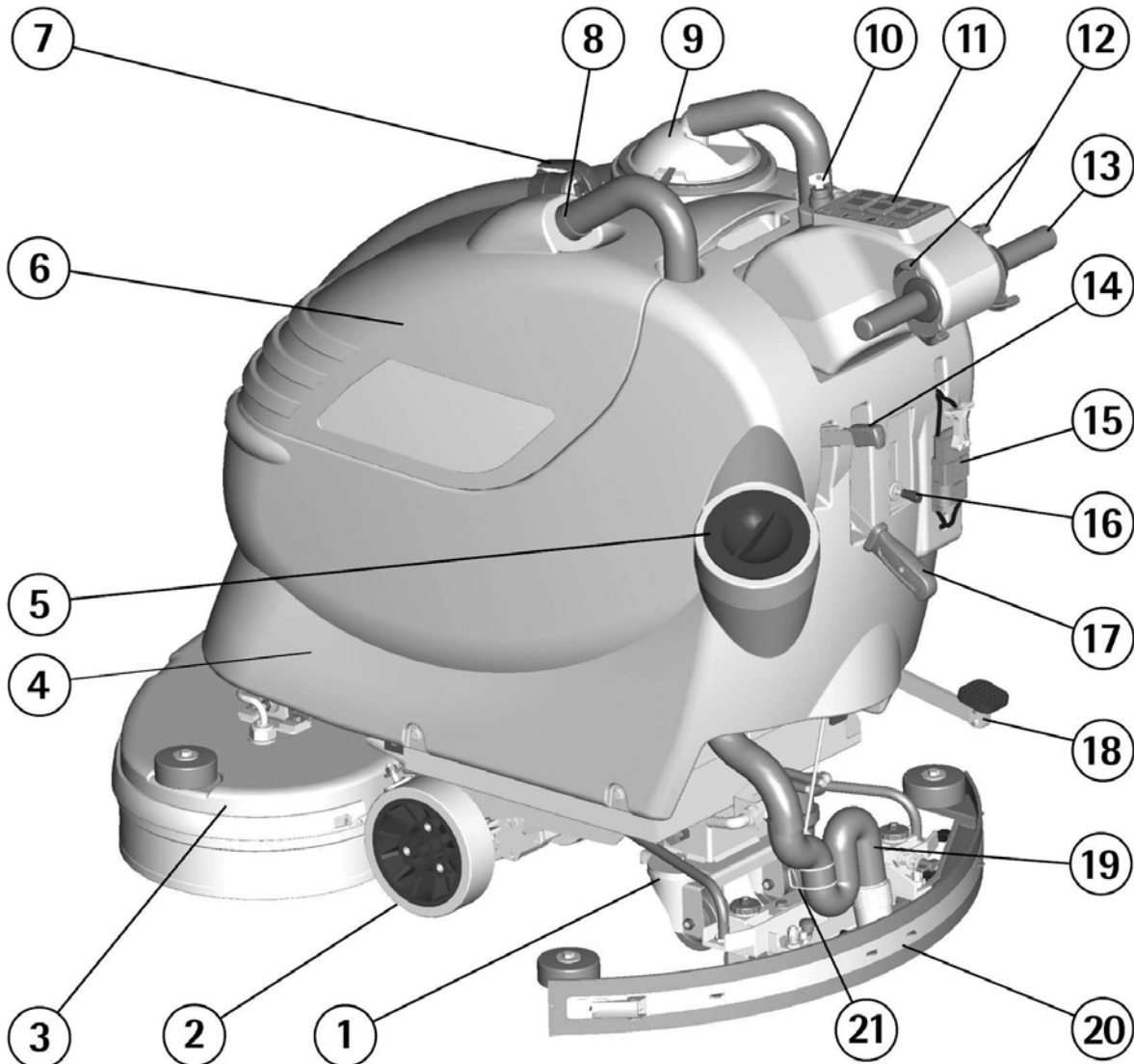

SYMBOLY ON THE MACHINE



Symbol denoting the solution valve.
Indicates the solution valve lever.



Symbol denoting the suction motor.
Indicates the switch of the suction motor.



Symbol denoting up - down of the squeegee.
Indicates the squeegee lever.

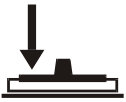

Symbol denoting the charge level of the batteries.

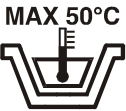

Indication of the maximum temperature of the solution detergent.
It is placed near the charging hole of the solution tank.



Symbol denoting the brush release.
Indicates the push button used to release automatically the brushes.



Symbol denoting the brush.
Indicates the switch of the brushes motor.



Symbol denoting the brake lever of the emergency and parking brake.



Symbol denoting the selection switch of the driving speed.



Symbol denoting the hour meter.



Symbol denoting the brake.
Indicates the signal lamp of the brake on.



Symbol denoting the crossed bin. Indicates that at the end of its activity, the machine has to be disposed conforming to the laws in force.

SYMBOLY ON THE MANUAL



Symbol denoting the open book.
Indicates that the operator has to read the manual before the use of the machine.



Symbol denoting the open book.
For the good functioning of the on-board battery charger (optional), read the manual of the constructor.



Warning symbol.
Read carefully the sections marked with this symbol, for the security of both the operator and the machine.



Symbol that indicates the obligations of disconnecting the system from the batteries by disconnecting the connector before operating on the machine.



Symbol that indicates the obligation of wearing safety glasses.



Symbol that indicates the obligation of wearing safety gloves.



Symbol that precedes an important information about the proper use of the machine.



Symbol that indicates operations that have to be carried out only by qualified personnel.

OPTIONAL ACCESSORIES

The optional accessories are:
3S – Solution Saving System (1);

Incorporated battery charger (2);
Squeegee "V"-type (3).

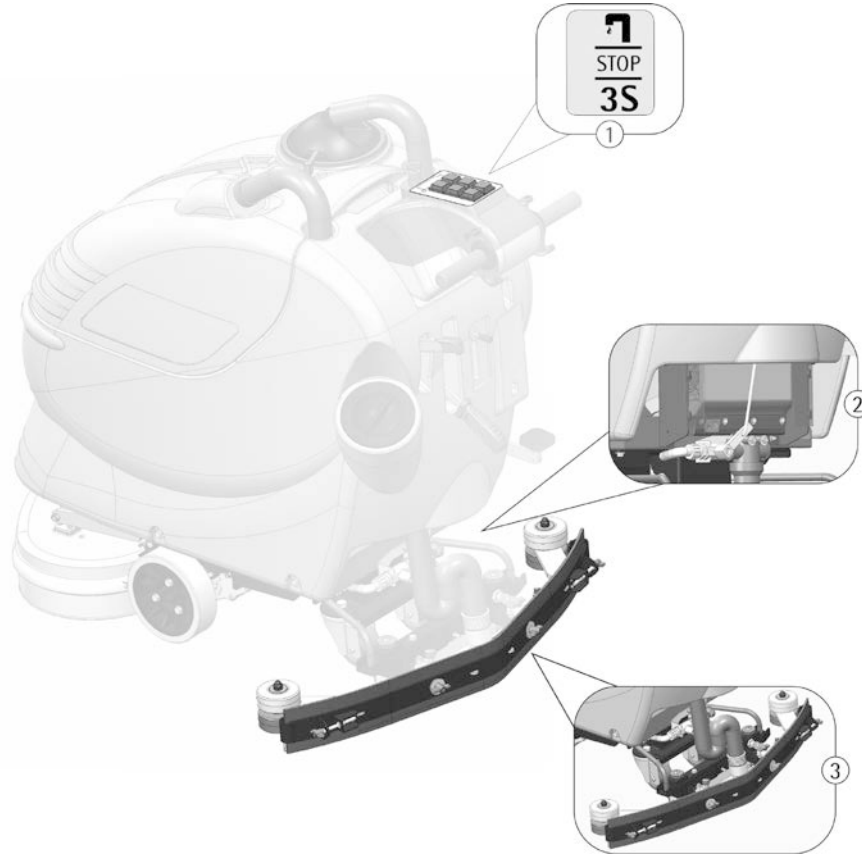

BEFORE USE

HANDLING OF THE PACKED MACHINE

The machine is supplied with suitable packing foreseen for fork lift truck handling.

brushes base 50 and 55:
 the total weight is 122kg (269 lbs.).
 The Packing dimensions are:
Base: 138 cm x 67 cm (54"x26")
Height: 119 cm (47")

brushes base 66:
 the total weight is 136kg (300 lbs.).
 The Packing dimensions are:
Base: 140 cm x 75 cm (55"x30")
Height: 120 cm (48")



Do not place more than 2 packings on top of each other.

UNPACKING OF THE MACHINE

1. Remove the external packing.
2. Unscrew the brackets (1+2) that secure the machine to the pallet.

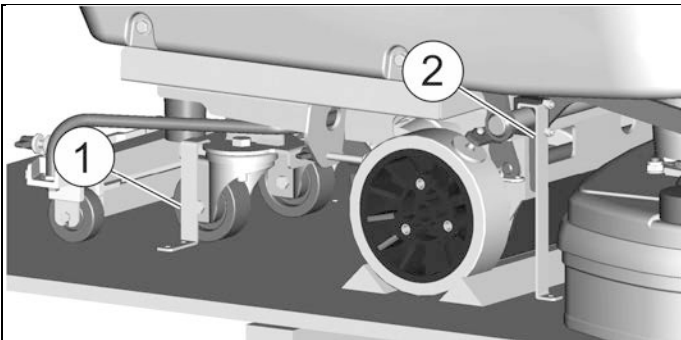

3. Provide for an inclined base.
4. Move the machine backwards, as indicated in the figure, avoiding heavy contacts to mechanical parts.

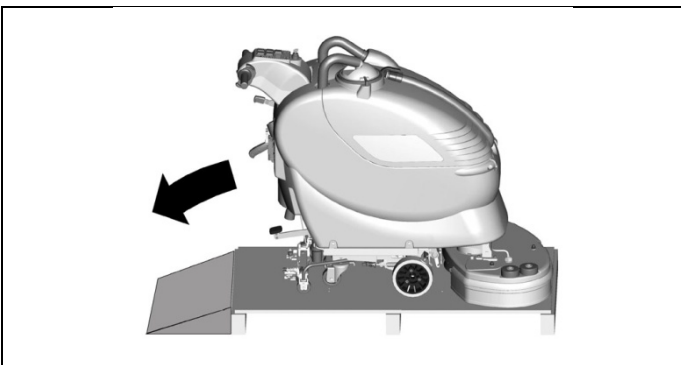

5. Keep the pallet and the brackets for eventual transport.

BATTERY INSTALLATION

The machine is equipped either with batteries in serial connection or elements of DIN-type assembled together and connected in series, placed in its appropriate compartment under the recovery tank and must be handled using suitable lifting equipment (due to weight, considering the type of batteries chosen, and coupling system). The batteries must be in accordance with CEI 21-5 Norms.

For batteries installation proceed as follows:

1. Take off the squeegee hose (1).
2. Take off the suction cover (2) after turning the blocking levers (3).

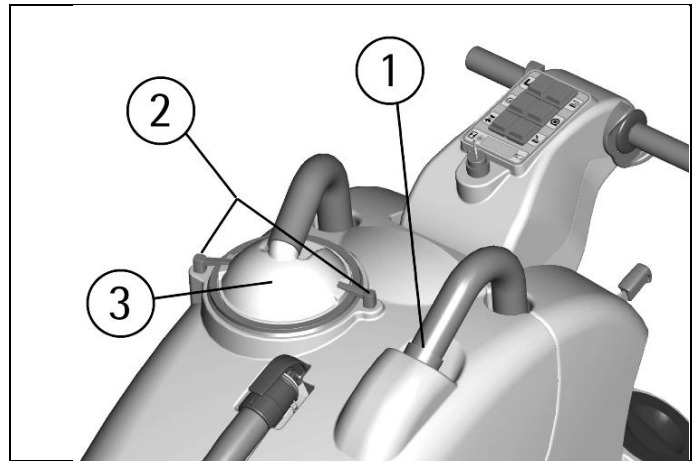

3. Lift the recovery tank by rotating it and fix it with the suitable bar (4).
4. Place the batteries in its compartment.

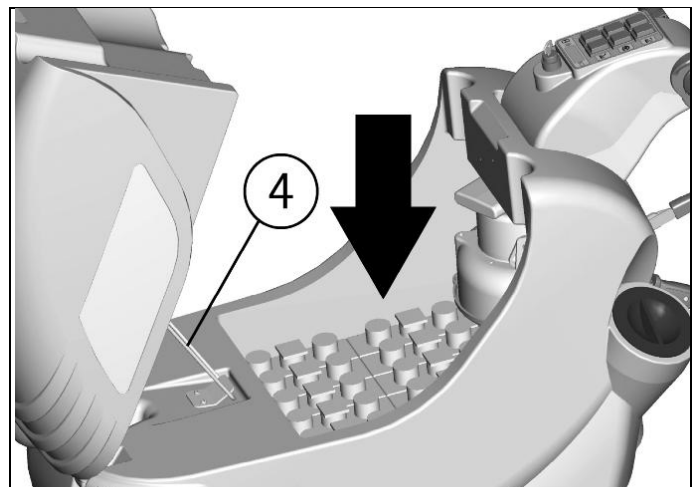

5. Connect the terminals, respecting the polarities, avoiding contact with other parts that could create short circuit.
6. Reassemble all parts.



The machine and its battery check card foresee the use of traditional lead batteries.

CHECK SETTING OF THE CHECK CARD ON THE DISPLAY (1).
 In case of GEL batteries installation, it is necessary to set the battery check card. Please contact the authorized technical assistance.

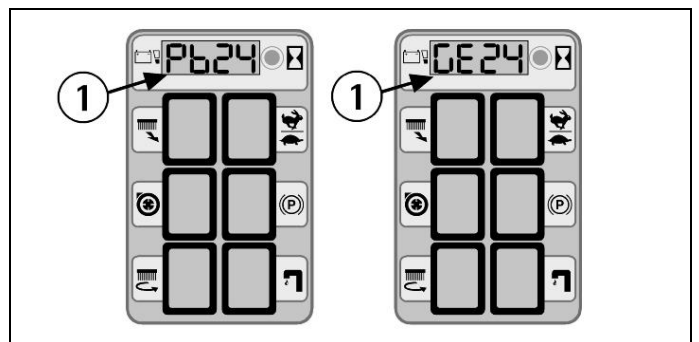

Strictly follow manufacturer/distributor indications for the maintenance and recharge of the batteries. All installation and maintenance operations must be executed by specialized staff, using suitable protection accessories.

BATTERY RECHARGER



Be sure that the battery recharger is suitable for the installed batteries both for their capacities and type (lead/acid or GEL and equivalent).

In versions not equipped with on-board battery charger it is recommended to use one with current suitable for the batteries used, SELV output voltage (Safety Extra Low Voltage) of 24Vdc and complying with IEC/EN 60335-1 and IEC/EN 60335-2-29.

In the plastic bag containing the use and maintenance you will find the coupling connector for the recharger. It must be assembled onto the cables of your recharger, following the instructions given by the manufacturer.

INCORPORATED BATTERY RECHARGER (OPTIONAL)

If the machine is equipped with the on-board battery recharger (see under "OPTIONAL ACCESSORIES") please refer to the instructions of the constructor of this accessory what the recharging operations concern.

The battery recharger is connected directly to the battery poles. During the recharging operations a device is activated which does not permit the machine's functioning.

The main cable of the battery recharger has a maximum length of two meters (6.5 ft.) and must be connected to a single-phase socket type CEE 7/7.

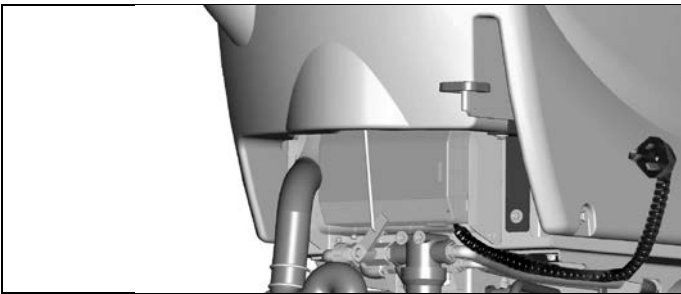

BATTERIES RECHARGING

Bring the machine on a levelled surface.

1. Plug in batteries connector (1) placed in the rear part of the machine, to the connector (3) of the battery recharger.
2. Proceed to the recharging keeping the tank lifted (see under paragraph "BATTERY INSTALLATION AND SETTING OF THE BATTERY TYPE" in "BEFORE USE").

Maintain the connection with the battery recharger until the indication of the end of charge is not visualized.

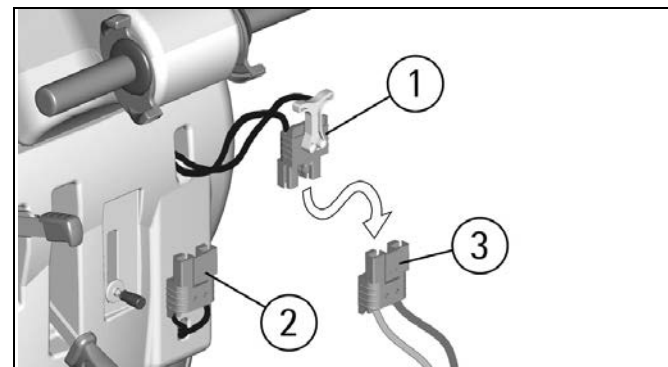

BATTERIES RECHARGING WITH ON-BOARD CHARGER (OPTIONAL)



Bring the machine on a leveled surface near to a single-phase socket (within 2m, 6.5 ft.) with tension 230V, frequency 50Hz (for USA 120V, 60Hz), nominal current 10A.

Switch off the machine and proceed as follows.

1. Insert the plug into the mains socket.
2. Proceed to the recharging keeping the tank lifted (see under paragraph "BATTERY INSTALLATION AND SETTING OF THE BATTERY TYPE" in "BEFORE USE").

3. Do not take off the plug from the mains socket until the indication of the end of charge is not visualized.
4. At the end of the recharging, take off the plug from the mains socket.

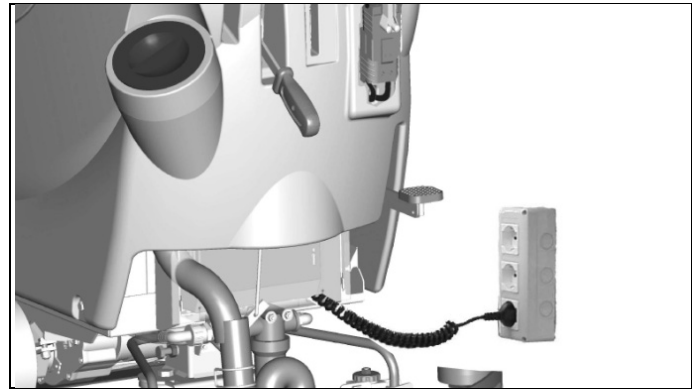

Never leave the batteries completely discharged even if the machine is not used. In case of lead/acid batteries, please check the electrolyte level every 20 recharging cycles and eventually top up with distilled water at the end of the recharge. Never leave the batteries discharged for more than two weeks.



Danger of gas exhalations and emission of corrosive liquids. Fire danger: do not approach with free flames.

BATTERIES DISPOSAL

It is compulsory to hand over exhaust batteries, classified as dangerous waste, to an authorized institution according to the current laws.

BATTERIES CHARGE LEVEL INDICATOR

WHEN THE MACHINE IS SWITCHED ON, ON THE DISPLAY APPEARS THE SETTING OF THE BATTERY CHECK CARD:

GE 24: check card set for GEL batteries.

Pb 24: check card set for lead batteries.

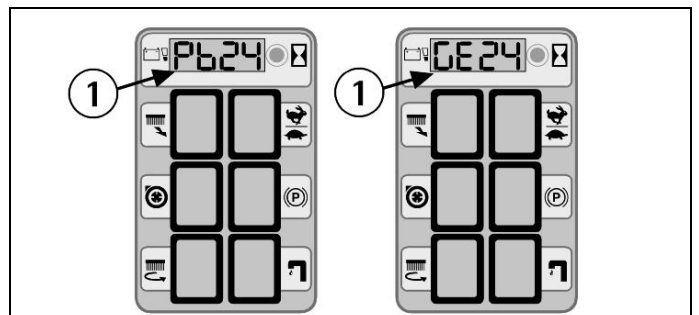

The batteries charge level indicator (1) is digital and indicates the percentage of the battery charge. 90 is the maximum charge, down to a minimum of 10, indicating every 10% decrease. When the charge level reaches 20%, the display starts blinking indicating the end of the battery charge.

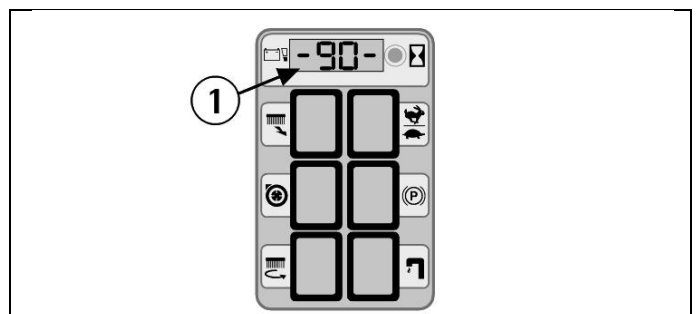



After a few seconds from the blinking of the four lines, the brushes motor stops automatically. With the remaining charge it is anyhow possible to finish the drying operation before proceeding to the recharge.

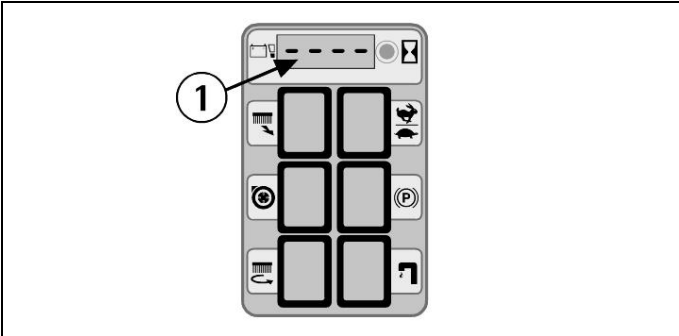

HOUR METER

The machine is equipped with an hour meter located on the same display of the battery charge level indicator (1). Keeping the button (2) pressed for more than 3 seconds, the first data indicates the working hours and after a few seconds the working minutes are shown.

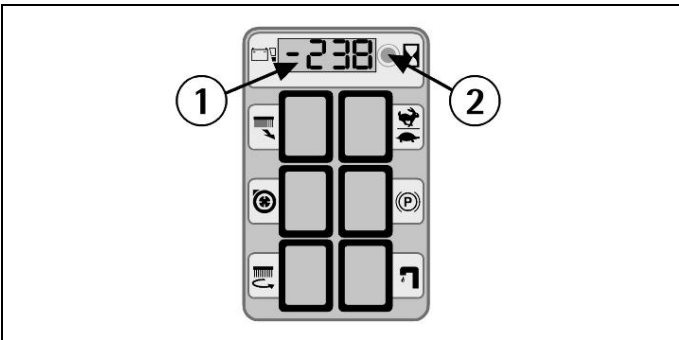

SQUEEGEE ASSEMBLY

With the squeegee support slightly lifted from the floor, slide the two stud bolts (1) placed on the upper part of the squeegee, inside the slots on the support. Block the squeegee by rotating the lever (2) clockwise. Insert the squeegee hose (3) into its coupling, respecting its position as indicated in the figure.

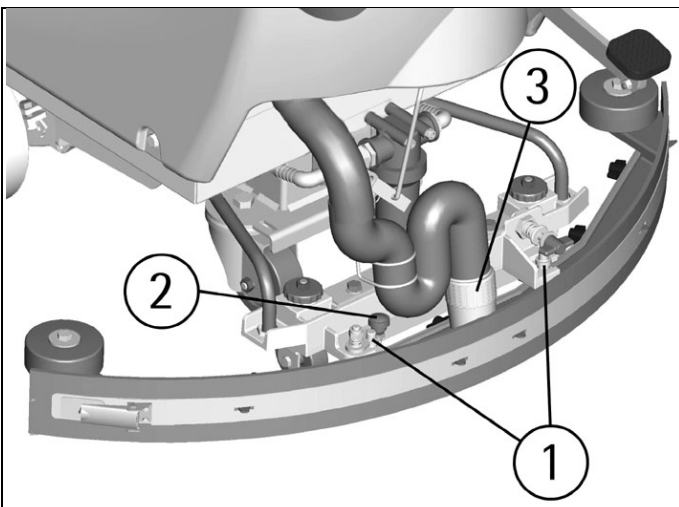

ADJUSTMENT OF THE SQUEEGEE

In order to have a perfect drying result through the squeegee, the rear rubber must have the lower bending uniformly adjusted in all its length. For the adjustment, it is necessary to put oneself in working condition and therefore the suction motor has to be switched on and the brushes have to function together with the detergent solution.

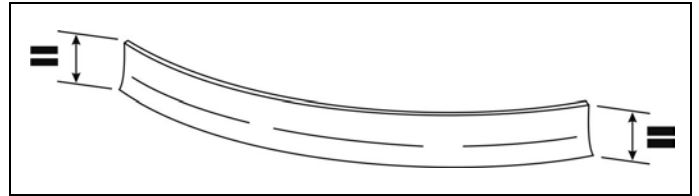

The lower part of the rubber is too much bent

Take off the pressure rotating the wing nut (4) counterclockwise.

The lower part of the rubber is not much bent

Increase the pressure rotating the wing nut (4) clockwise.

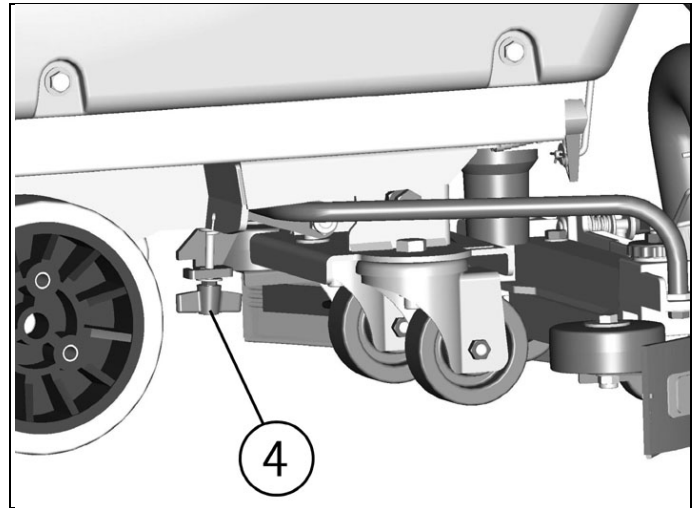

The bending is not uniform

Adjust the squeegee inclination rotating counterclockwise the wing nut (5) to increase the bending in the central part, or clockwise to increase the bending on the extremities.

Height adjustment

Once that the pressure and inclination of the squeegee has been adjusted, it is necessary to fix this optimum condition making touch slightly the wheels onto the floor. Rotate counterclockwise the registers (6) to lower the wheels or clockwise to raise them. Both wheels must be adjusted in the same measure. A label placed near the two registers (6) indicates rotation sense to increase or reduce the height.

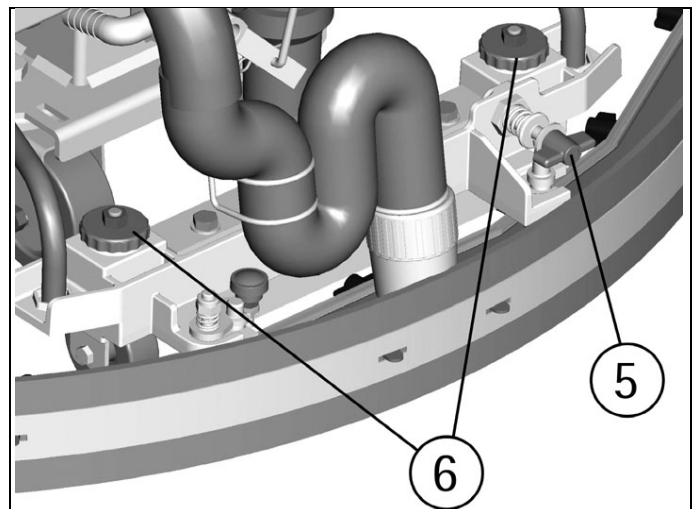

SPLASH GUARD ASSEMBLY

The two splash guards have to be assembled onto the brushes base group. Insert the metal strips inside the suitable slots present on the rubber. Place the round hole at the flat extremity of the strip onto the screw placed in the front part of the brushes base group. Secure the strips through the nut blocking it.



(brushes base 50 and 55)
 Hook the spring in the rear part of the brushes base group to the slot placed at the extremity of the metal strip still free. Please act as above for both the splash guard rubbers, paying attention to reduce to the minimum the gap between the two rubbers in the front part of the brushes base group.
 With brushes assembled, the splash guard must slightly touch the floor.

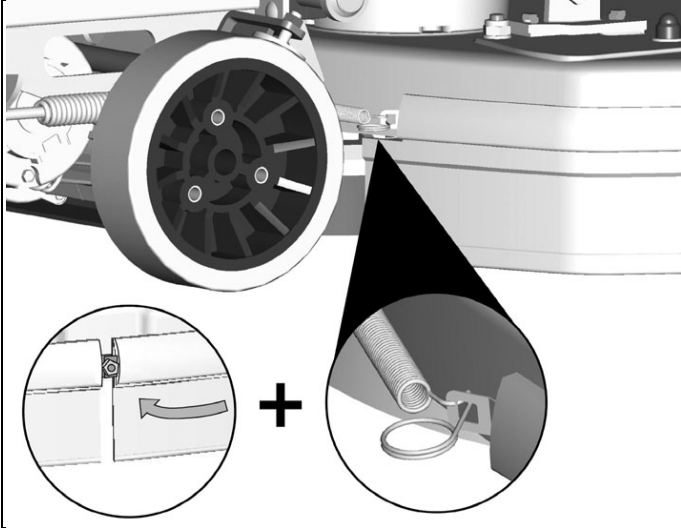

(brushes base 66)
 Block the coupling levers (2) in the rear part of the brushes base group to the slots placed at the extremity of the metal strips still free. Please act as above for both splash guard rubbers, paying attention to reduce to the minimum the gap between the two rubbers in the front part of the brushes base group.
 With brushes assembled, the splash guard must slightly touch the floor.

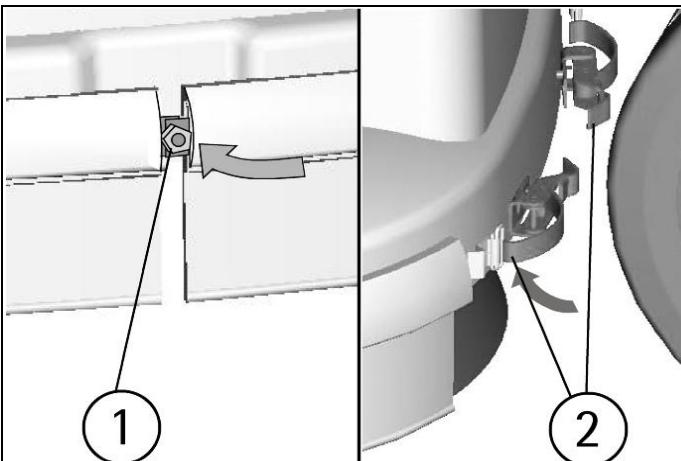

BRUSHES ASSEMBLY



Acting upon the pedal (13) lift the brushes base group.

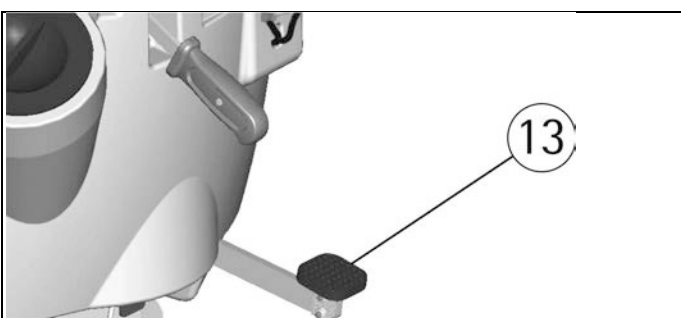

With the brushes base group in lifted position, insert the brushes into their plate seat underneath the brushes base turning them until the three metal buttons are properly seated in their slots; rotate energetically the brushes to push the button towards the coupling spring until they get blocked.
 The figures show the rotating sense for brushes coupling.

(brush base 50)

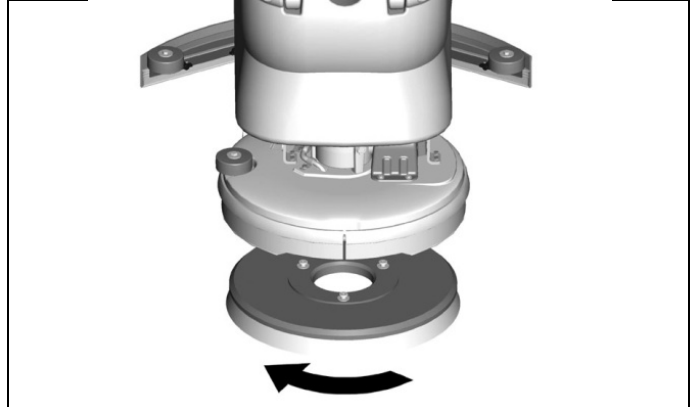

brushes base 55 and 66)

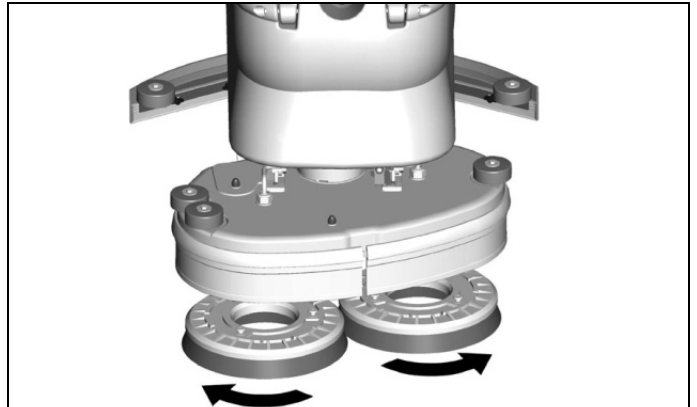

For a longer life of the brushes we suggest to invert daily their position. Whenever brushes were deformed we suggest to reassemble them in the same position, avoiding that the different inclination of the bristles causes excessive motor overload or troublesome vibrations.

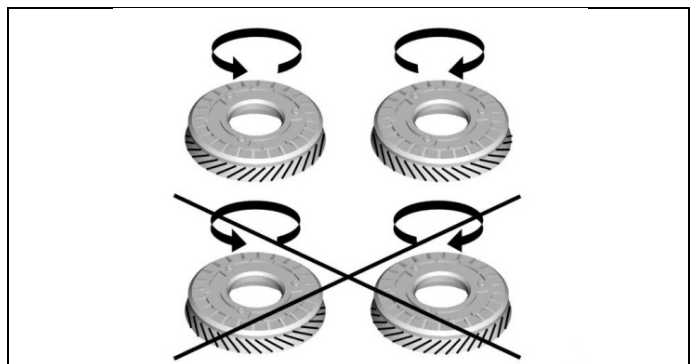



FLOOR CLEANING

CONNECTION OF THE BATTERIES TO THE MACHINE

Plug in the batteries connector (1) to the machine connector (2), placed in the rear part of the machine.

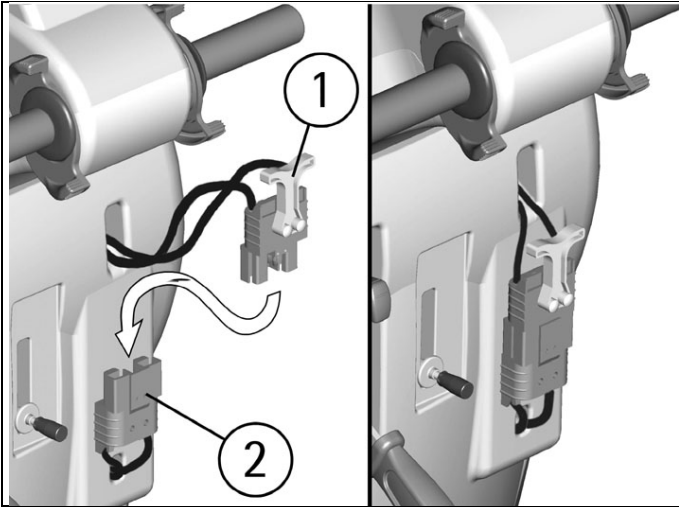

RECOVERY TANK



Check that the cover of the suction filter (1) is correctly secured, after rotating the levers (2) and that the suction motor hose is correctly connected.

Verify also that the squeegee hose (4) is correctly inserted into the seats and that the exhaust hose plug (5) placed in the front part of the machine, is closed.

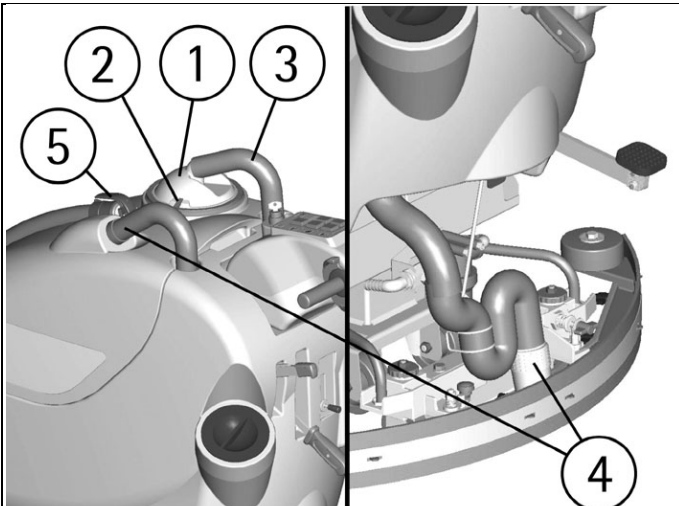

DETERGENT SOLUTION TANK

The solution tank is provided with an inspection opening. This permits to clean the exit point of the detergent solution. Be sure that the cap is well tightened after the cleaning.

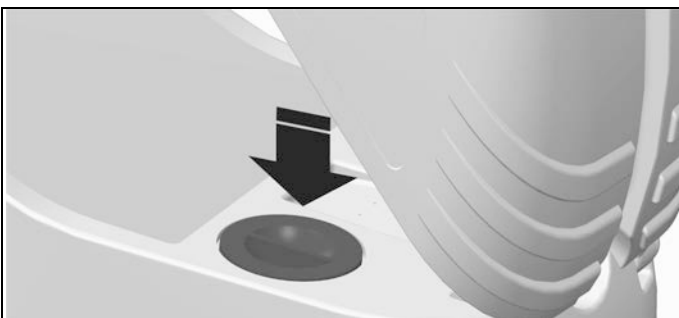

The capacity of the detergent solution tank is indicated in the technical data.

Open the screw plug (1) placed in the rear left part of the machine and fill the detergent solution tank with clean water at a maximum temperature of 50°C (122°F). Add the liquid detergent in the percentage and conditions foreseen by the manufacturer. To avoid excessive foam presence, which could cause problems to the suction motor, use the minimum percentage of detergent. Screw down the plug to close the tank. Always use low-foam detergent. To safely avoid the production of foam, before starting work introduce a minimum quantity of anti-foaming liquid into the recovery tank. Do not use pure acids and use only professional products suitable for cleaning with scrubbing machines.

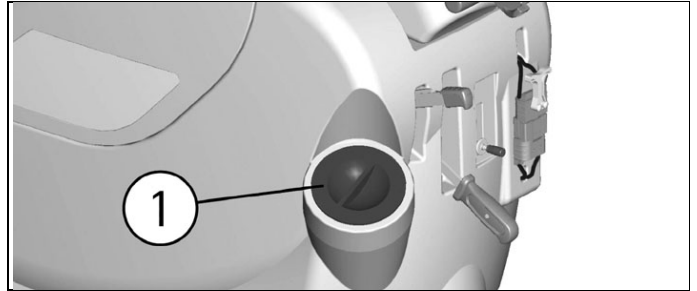

Use always low foam detergent. To avoid foam presence, before starting working operation, introduce into the recovery tank a minimum quantity of anti-foam product. Never use pure acid.

3S SYSTEM "SOLUTION SAVING SYSTEM" (OPTIONAL)

The system is composed by a hydraulic circuit parallel to the traditional one which can be enabled or disabled directly from the instrument board through a 3-position switch with the following functions:

- (1) = Position solution valve with traditional functioning with variable water flow that differs by the opening of the solution valve.
- (2) = Position STOP with functioning without flow (drying only).
- (3) = Position 3S with functioning with optimal fixed flow.

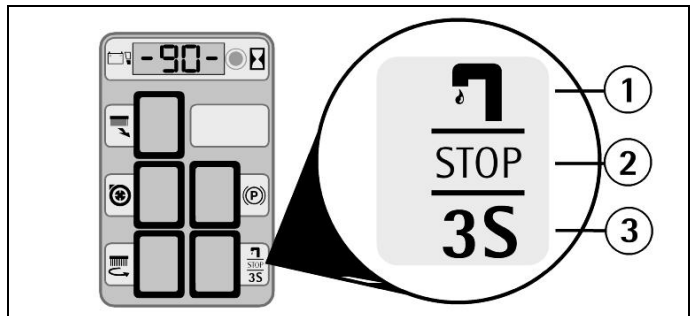

The hydraulic circuit of the 3S system is independent and it is provided with a proper filter which has to be cleaned regularly. For the cleaning it is necessary to unscrew the plug as shown in the figure and clean the inside filter with a water jet.

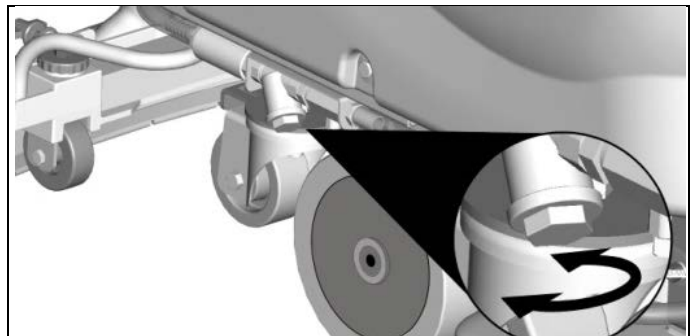



SELECTING AND WORKING WITH OZONE (OPTIONAL)

The machine can produce water with an ozone level high enough to disinfect the surfaces cleaned. In order to operate the ozone system, the best way, proceed as follows:

1. Make sure that the inside of the solution tank is clean, eventually rinse it making at least a couple of fillings and depletions.
2. Fill the solution tank with tap water (do not add any detergent).
3. Turn on the ozone generator by pressing the proper switch identified by the appropriate symbol (1) located on the control panel and set the different controls for the work of the machine.
4. Start working. When the solenoid valve starts working, the warning light (2) lights up indicating ozone production.

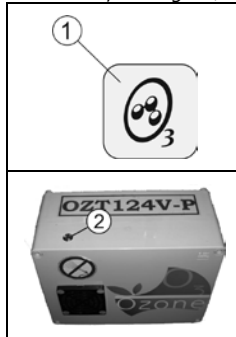

Ozone is a very penetrating gas and it can be irritating.

The ozonated water is strongly oxidizing, therefore in order to protect from oxidization (rust) the metal parts of the machine, it is better to rinse with water all the lower parts of the machine at least once a week.

At the end of the work, it is not necessary to empty the solution tank.

STARTING OF THE MACHINE

1. Turn the key (8) clockwise.
2. Check the battery type and the charge level on the display (1).
3. Press the brushes motor switch (5).
4. Press the suction motor switch (6).
5. Press the solenoid valve switch (4).

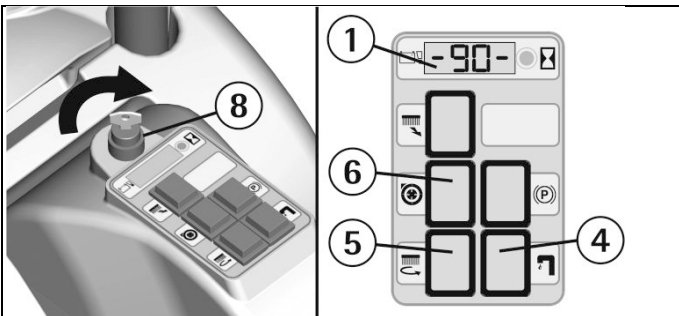

Models equipped with the 3S system (optional), it is necessary to press the suitable switch to activate the detergent solution supply by choosing between the traditional adjustment system through the solution valve or the system of fixed optimum supply (see under "3S SYSTEM SOLUTION SAVING SYSTEM").

6. Acting upon the brushes base lifting pedal (13) lower the brushes base.
7. Acting upon the solution valve lever (11) open and adjust the solution detergent flow. The water starts to flow automatically acting upon the levers drive control (9). On the instrument board the indicator of the solenoid valve switch (4) will turn on. Releasing these levers, the flow will stop.
8. Acting upon the squeegee lifting lever (12) lower the squeegee.
9. Acting upon the levers drive control (9) the machine starts to move, the brushes start to rotate and the squeegee starts to dry.
10. During the first stretches check that the squeegee adjustment guarantees a perfect drying action and that the detergent solution flow is appropriate. It has to be sufficient to wet the floor uniformly avoiding the leakage of detergent from the splash guards. Always consider that the correct quantity of solution detergent depends on type of floor, dirtiness and machine speed.

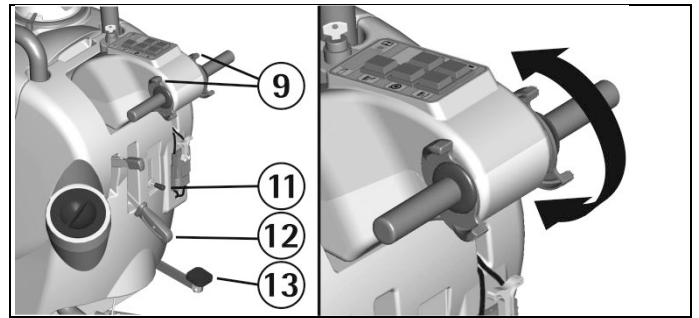

FORWARD MOVEMENT

The traction of the machine is given through an electronically controlled motor.

To move the machine, switch on the key and then rotate the levers drive control placed on the handle bar, in forward you obtain the forward drive, in reverse the backwards movement is obtained. The control acts in a progressive way, therefore it is possible to graduate the speed depending on each requirement rotating the lever whatever it is necessary. During reverse motion the speed is reduced.

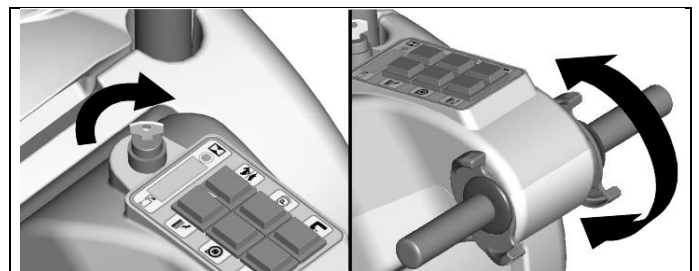

Moving the machine backwards, make sure that the squeegee is lifted.

SPEED ADJUSTMENT

Two values of the maximum drive working speed in forward movement can be chosen.

Set the wanted speed through the speed selection switch (14).

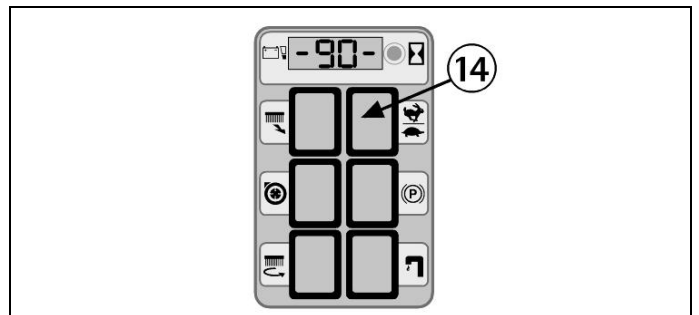

WORKING BRAKE

To stop the machine during normal working situation, it is sufficient to release the levers drive control, as the machine is equipped with an electronic braking system. The brushes and the detergent solution flow stop automatically.

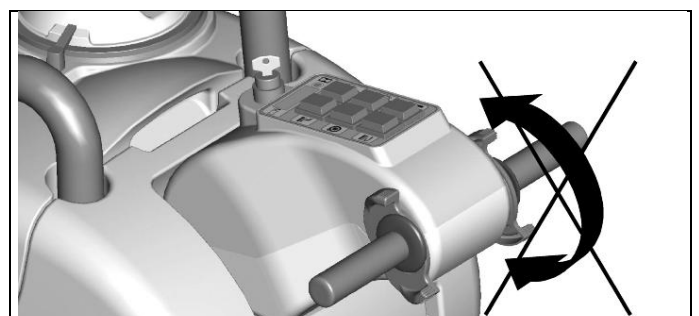



EMERGENCY BRAKE

In case of an emergency, an immediate stop can be obtained acting upon the lever of the emergency and parking brake (10) by pushing it downwards.



This control blocks the machine immediately. The emergency brake functions also as a parking brake. To start again to work, release the lever by unblocking the parking button on the lever itself and act again upon the levers drive control.

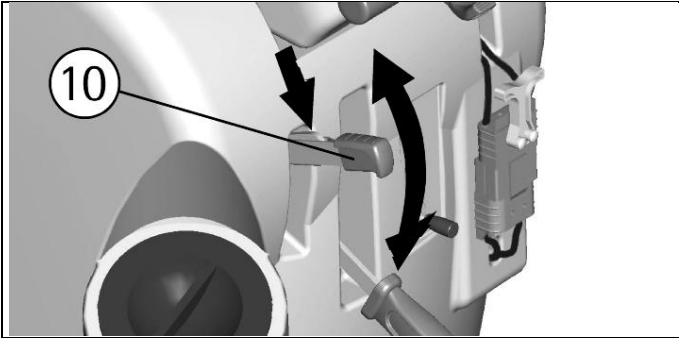

ADJUSTMENT OF THE BRUSHES PRESSURE

Through the register (1) it is possible to adjust the brushes pressure on the cleaned surface.

By turning the wing nut clockwise, the pressure increases, rotating the wing nut counterclockwise, the pressure decreases.

This device allows a more efficient cleaning action also on very difficult and dirty surfaces.

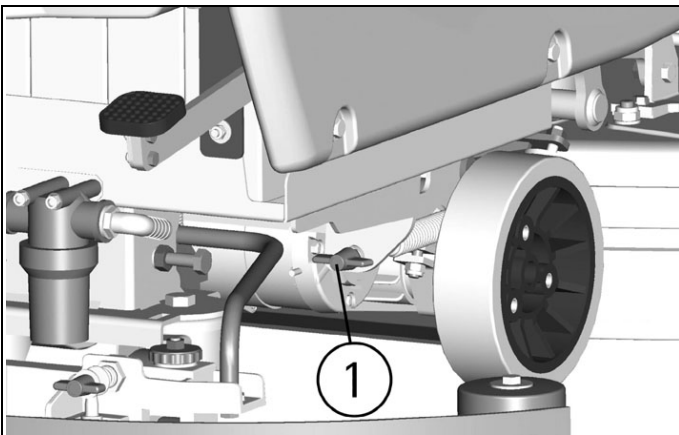

In order not to overload the brushes motor, it is convenient to reduce the brushes pressure going from smooth floors to rough ones (ex. concrete).

BRUSHES MOTOR OVERLOAD PROTECTION DEVICE

The machine is equipped with an adjustment of the brushes pressure. The presence of a protective device indicating the overload is activated on the display showing the bad functioning with "AL01". Check the pressure regulation as indicated in the previous paragraph.



To restore the functioning of the brushes motor, turn off and on again the machine acting upon the key switch.

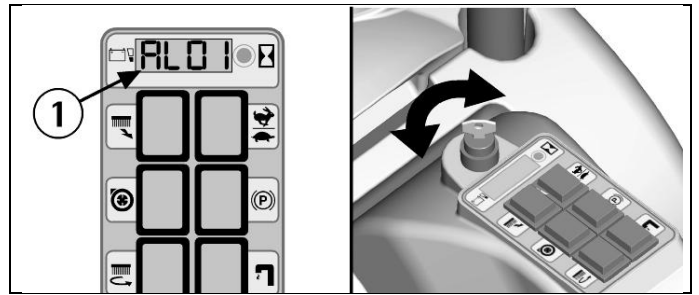

OVERFLOW DEVICE



In order to avoid serious damages to the suction motor, the machine is equipped with a float that intervenes when the recovery tank is full, closing the suction hose and stopping the suction.

When this happens, it is necessary to empty the recovery tank.

1. Hold the exhaust hose placed in the front part of the machine.
2. Take off the exhaust plug acting upon its lever and empty the recovery tank into appropriate containers, according to the standard norms.

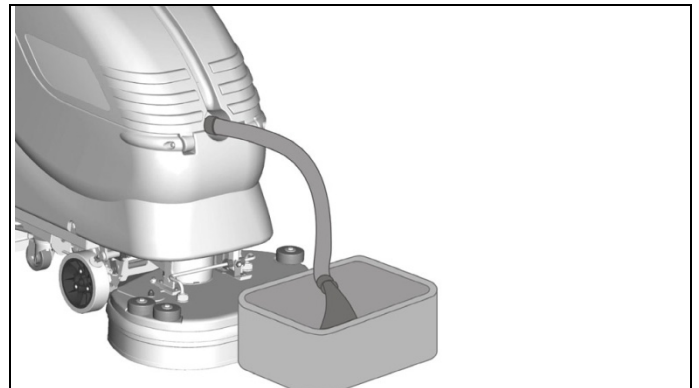

SIGNAL DETERGENT SOLUTION RESERVE (H2O ON THE DISPLAY)

When the indication H2O on the display appears, this means that the detergent is getting low corresponding to 10% of the maximum capacity of the solution tank.

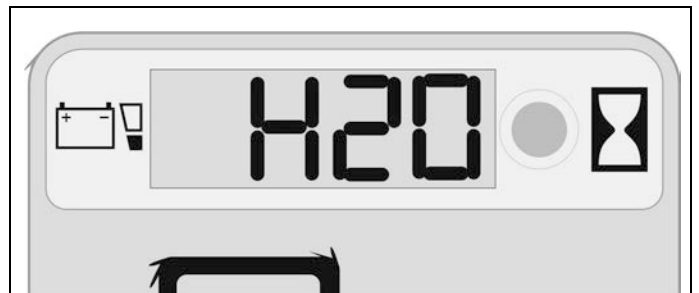



STOP OF THE MACHINE AFTER CLEANING OPERATION

Before executing any type of maintenance:

1. Turn the brushes motor switch off (5).
2. Turn the suction motor switch off (6).
3. Lift the brushes base acting upon the pedal (13).
4. Lift the squeegee acting upon the lever (12).
5. Bring the machine to an appropriate place for tanks draining.
6. Turn the key (8) counterclockwise.
7. Insert the parking brake (10).

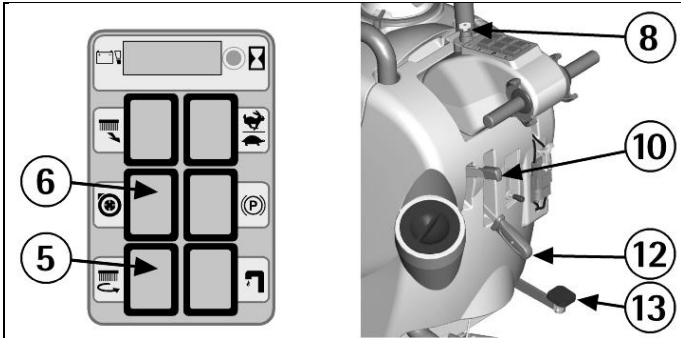

DAILY MAINTENANCE

RECOVERY TANK CLEANING



1. Hold the exhaust hose placed in the front part of the machine.
 2. Take off the exhaust plug acting upon its lever and empty the recovery tank into appropriate containers.
 3. Take off suction cover (1) after rotating the blocking levers (2).
 4. Take off the filter and filter protection.
- Rinse the tank with water jet.

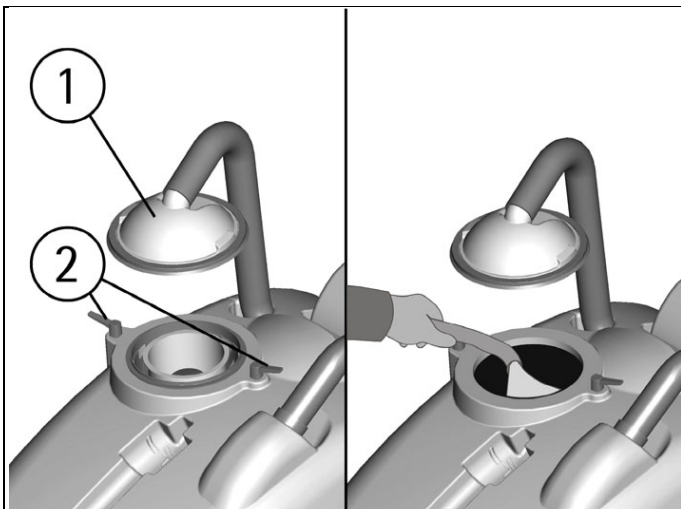

SUCTION FILTER CLEANING

1. Take off suction cover (1) after rotating the blocking levers (2).
2. Take off the filter and filter protection.
3. Clean all parts with a water jet especially inside surfaces and filter bottom.
4. Carry out cleaning operations carefully.
5. Reassemble all parts.

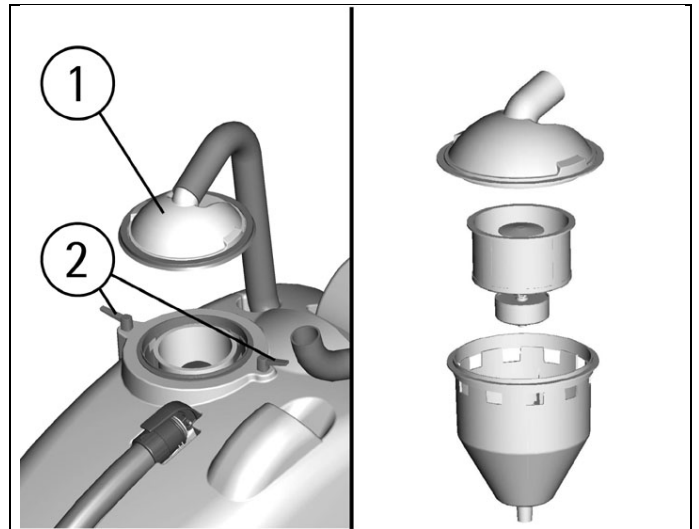

AUTOMATIC DISASSEMBLY OF THE BRUSHES

The model with the brush base 50 is equipped with a device that permits to release automatically the brush.

1. Lift the brush base lowering the pedal (13).
2. Turn the key clockwise.
3. Press the switch of the brush motor (5).
4. Keeping the release button (7) pressed, act with an impulse upon the levers drive control.

In this way, the brush will rotate for a few instants and then will drop to the floor.

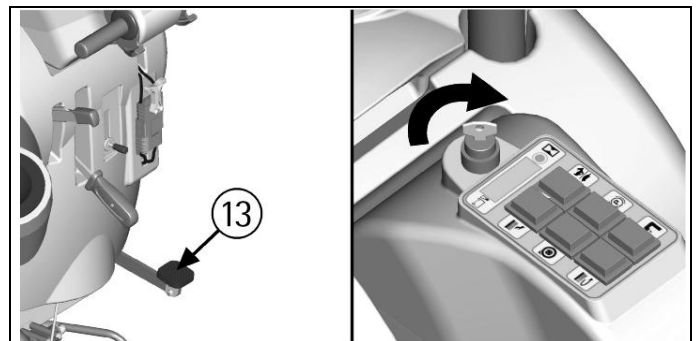

MANUAL DISASSEMBLY OF THE BRUSHES



If the manual disassembly is chosen for the model with brush base 50, or in the models with brushes base 55 and 66, whose brushes can be taken off only manually, proceed as follows:

1. Lift the brushes base lowering the pedal (13).
2. Turn the key counterclockwise.
3. Take off the electric supply to brushes motor unplugging the battery connector (1).

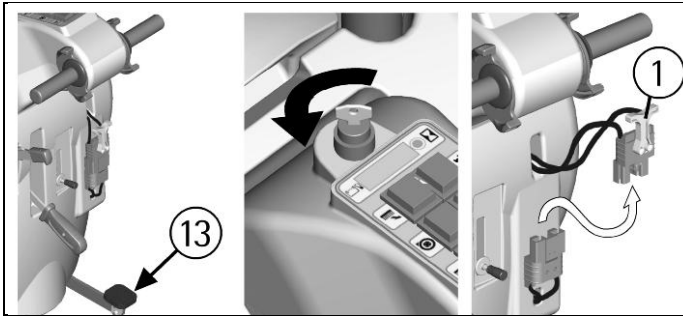

4. With the brushes base in lifted position, turn the brush in its rotating sense as indicated in the figure, until it is released from the brush holder plate seat as indicated in the figure. The figures show rotating sense for brushes release.

(brush base 50)

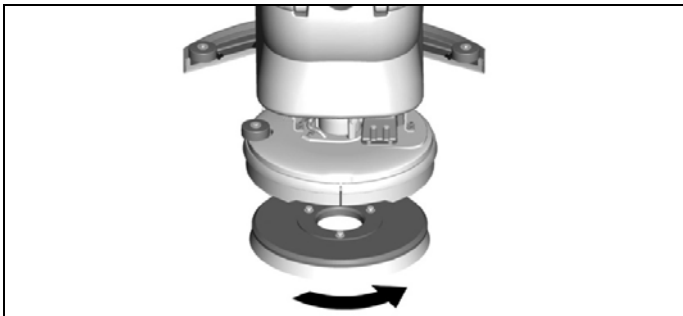

(brushes base 55 and 66)

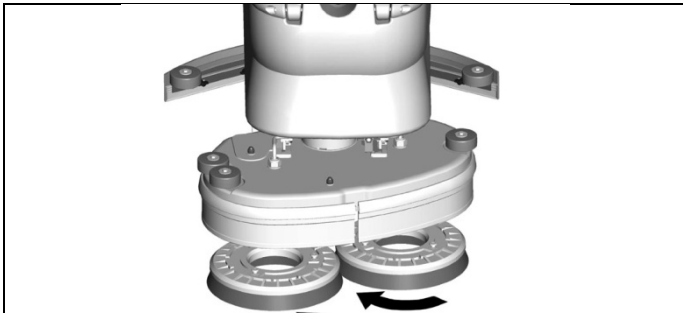

BRUSHES CLEANING

Disassemble the brushes and clean them with a water jet (check under paragraph of "BRUSHES DISASSEMBLY").

SQUEEGEE CLEANING



Keeping the squeegee clean guarantees always the best drying action. For its cleaning it is necessary to:

1. Take off the squeegee hose (3) from the coupling.
2. Disassemble the squeegee from the support rotating the lever (2) counterclockwise sliding the stud bolts (1) in their slots.
3. Clean with care the internal part of the squeegee inlet eliminating eventual dirt residuals.
4. Clean with care the squeegee rubbers.
5. Reassemble all parts.

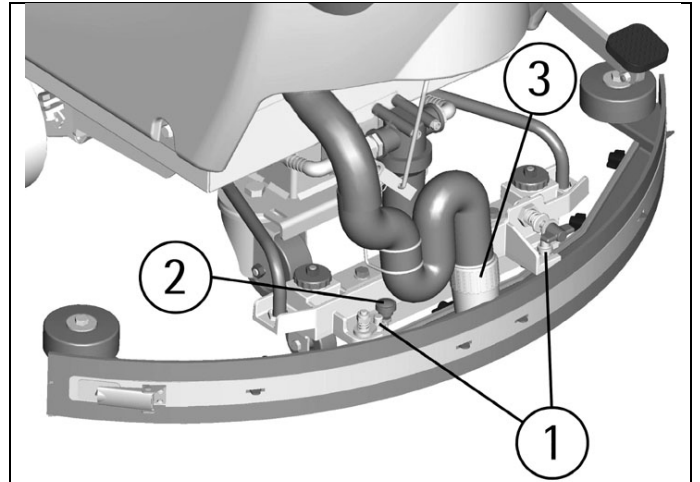

WEEKLY MAINTENANCE

REAR SQUEEGEE RUBBER CHECK



Check the squeegee rubber wear and eventually turn or replace it.

For the replacement it is necessary to:

1. Lift the squeegee acting upon the lever (12).
2. Release the hook (1) of the rubber holder blade and take the rubber off.
3. Turn the rubber to a new side or replace it.

To reassemble the squeegee repeat reverse the operations above mentioned, inserting the rubber on the guides (2) and blocking it with the rubber holder blade.

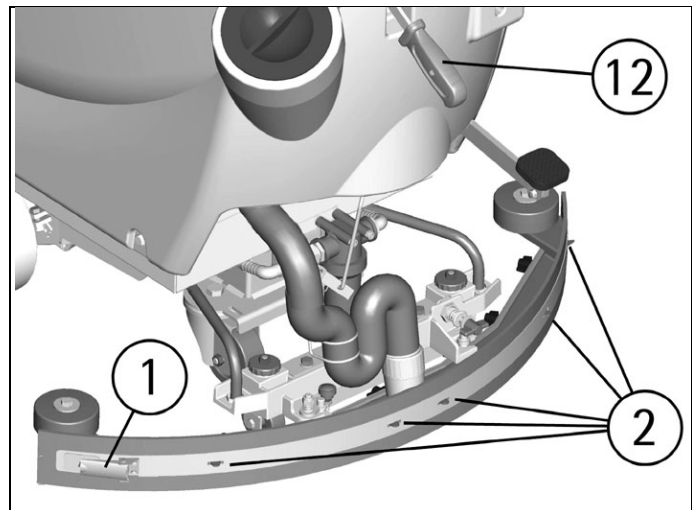

SQUEEGEE HOSE CLEANING



Weekly or in case of insufficient suction, it is necessary to check that the squeegee hose is not obstructed. Eventually, to clean it, proceed as follows:

1. Take off the hose from the squeegee coupling (1) and release the guide spring of the squeegee hose (2).
2. Wash the inside of the hose with a water jet, from the squeegee hose side.
3. To reassemble the hose repeat reverse the operations above-mentioned.

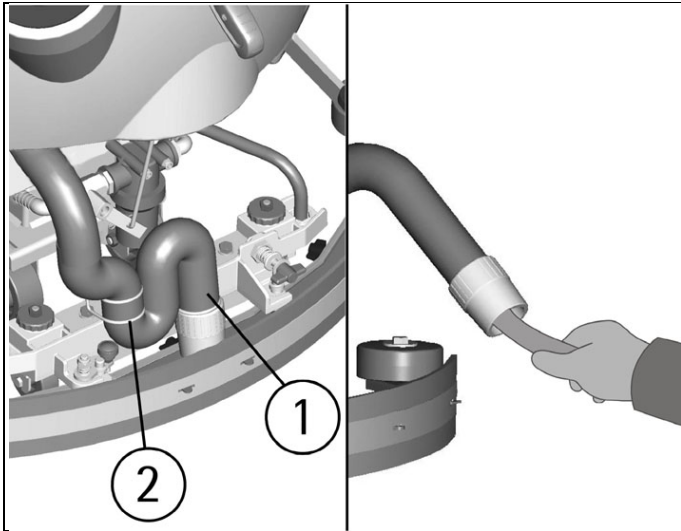

SQUEEGEE "V" TYPE (OPTIONAL)

Alternatively to the standard squeegee, a "V"-shaped squeegee is available, especially indicated for floors with large joints. This squeegee is interchangeable with the standard one, same assembly on the machine, same adjustment in height, pressure and inclination. Different though are the methods in assembly and disassembly of the squeegee rubbers.

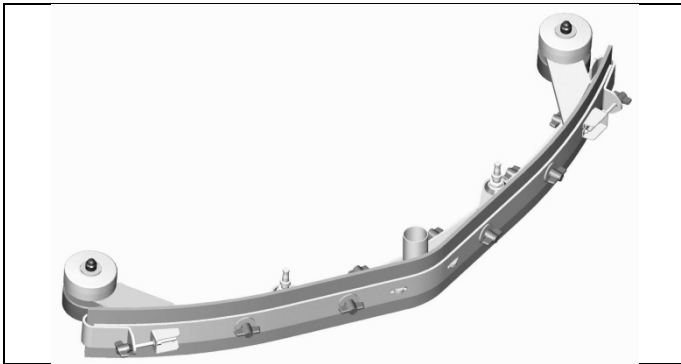

SQUEEGEE "V" TYPE (OPTIONAL): REAR RUBBER CHECK



Check the squeegee rubber wear and eventually turn or replace it. For the replacement it is necessary to:
Lift the squeegee acting upon the lever (12).

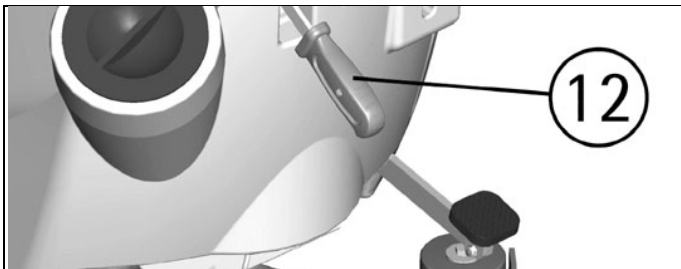

1. Unscrew the tie rods (1) on the terminals (2) of the rubber holder blade and disengage the terminals.
 2. Unscrew the wing nuts (3) and take off the rubber holder blade (4).
 3. Turn the rubber (5) to a new side or replace it.
- To reassemble the squeegee repeat reverse the operations above mentioned, inserting first the rubber (5) into its guides, then positioning the rubber holder blade and finally screwing down all wing nuts and the tie rods of the two terminals.

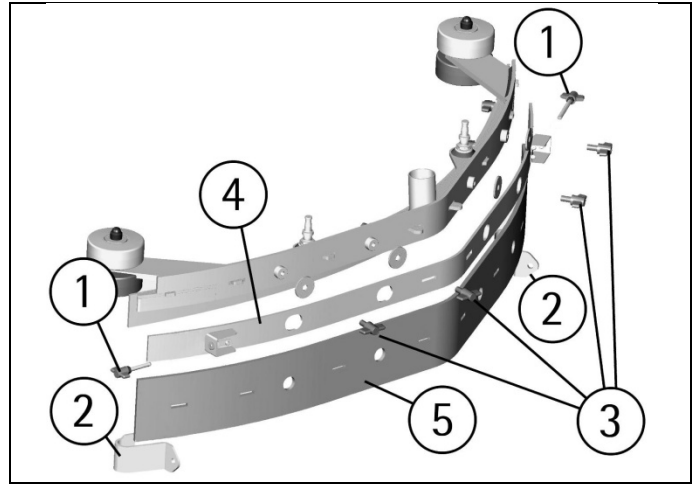

CLEANING OF SOLUTION TANK AND FILTER



1. Bring the machine to an appropriate place for tanks draining.
2. Unscrew the solution tank cap (1).
3. Unscrew the exhaust plug (2).
4. Rinse with a water jet the solution tank.
5. Rinse the solution tank filter placed inside the exhaust plug (2).
6. Reassemble all parts.

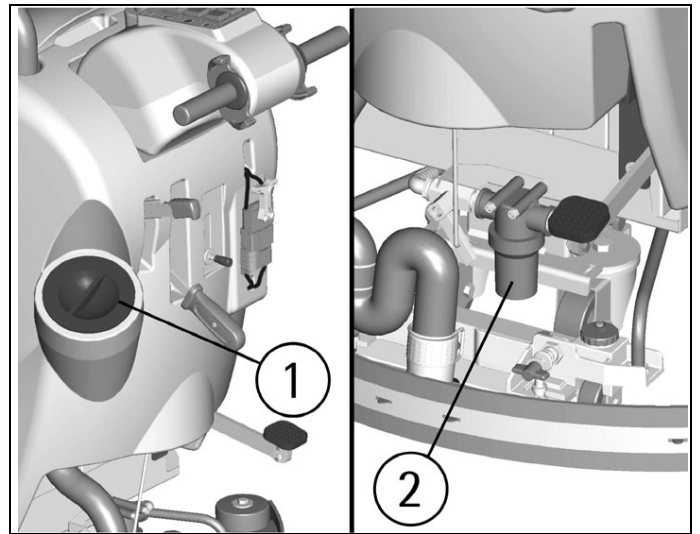

TWO-MONTHLY MAINTENANCE

FRONT SQUEEGEE RUBBER CHECK



- Check the wear of the squeegee rubber and eventually replace it. For the replacement it is necessary to:
1. Take off the squeegee hose (3).
 2. Disassemble the squeegee from the support rotating the levers (2) counterclockwise by sliding the stud bolts (1) in their slots.
 3. Unscrew the wing nuts (4) in the front part of the squeegee.
 4. Take off the rubber holder blade.
 5. Replace the front rubber.
 6. Reassemble all parts.

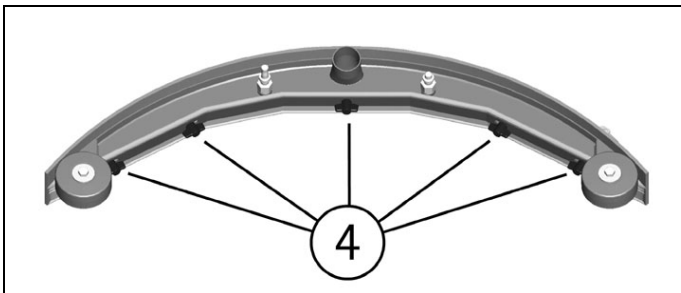
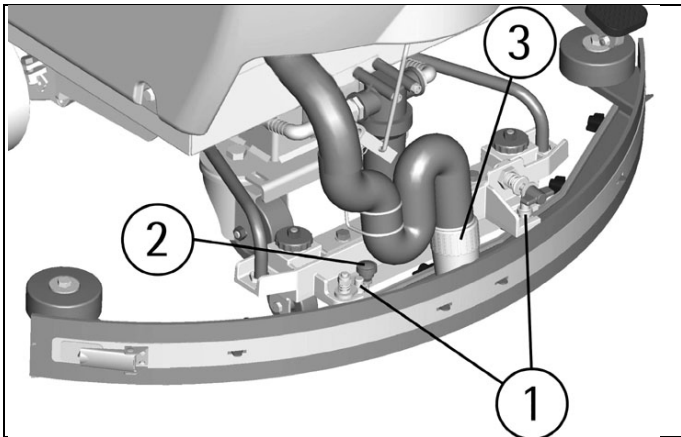

SQUEEGEE "V" TYPE (OPTIONAL): FRONT RUBBER CHECK



Check the squeegee rubber wear and eventually replace it. For the replacement it is necessary to:

1. Disassemble the squeegee from the support as indicated under "SQUEEGEE CLEANING".
2. Unscrew the tie rods (1) on the terminals (2) of the rubber holder blade and disengage the terminals.
3. Unscrew all wing nuts (6) and take off the rubber holder blade (7).
4. Take off the rubber (8) and replace it.

To reassemble the squeegee repeat reverse the operations above mentioned, inserting first the rubber (8) into its guides, then positioning the rubber holder blade and finally screwing down all wing nuts and the tie rods of the two terminals.

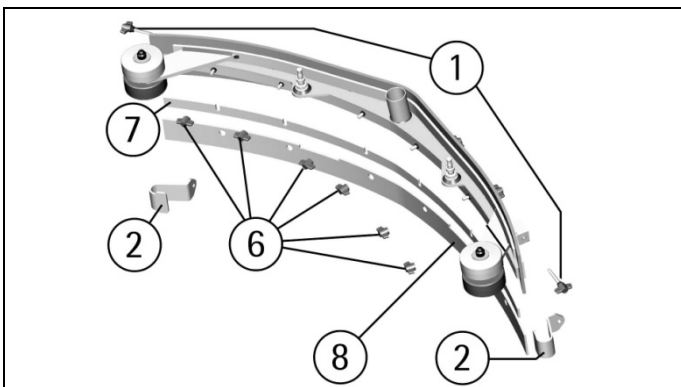

SIX-MONTHLY MAINTENANCE

SPLASH GUARD REPLACEMENT



(brushes base 50 and 55)

1. Release the spring in the rear part of the brushes base group from the slot placed at the extremity of the metal strip.
2. Replace the splash guard rubbers and follow assembling instructions at "SPLASH GUARD ASSEMBLY" paragraph.

With brushes assembled, the splash guard must slightly touch the floor.

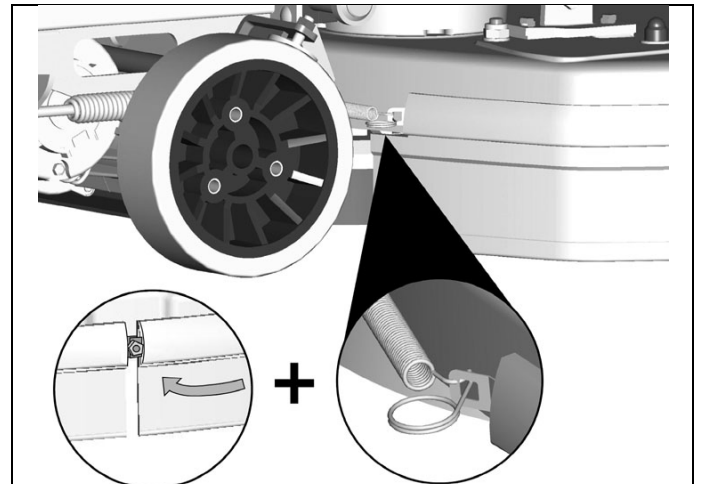

(brushes base 66)

1. Open the hooks in the rear part of the brushes base group from the slot placed at the extremity of the metal strip.
2. Replace the splash guard rubbers and follow assembling instructions as under paragraph "SPLASH GUARD ASSEMBLY".

With brushes assembled, the splash guard must slightly touch the floor.

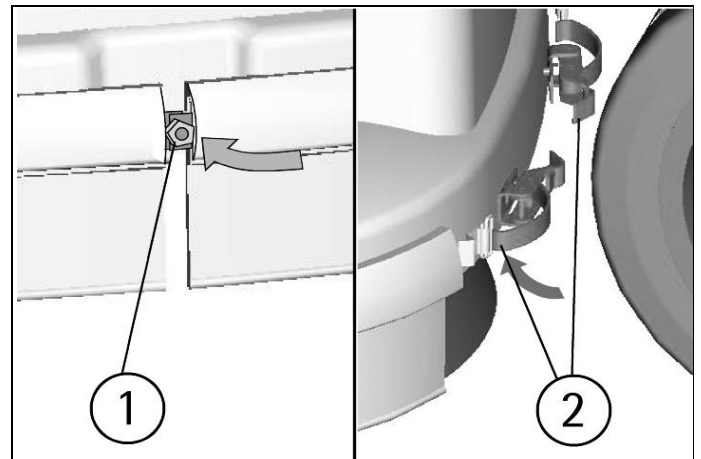

CHECK OF THE BRAKE

Check the braking efficacy and that both pads (1) which act upon the traction wheels, in resting position, have got a distance of not more than 3mm from the wheels. If necessary, adjust them through the fixing nuts (2).

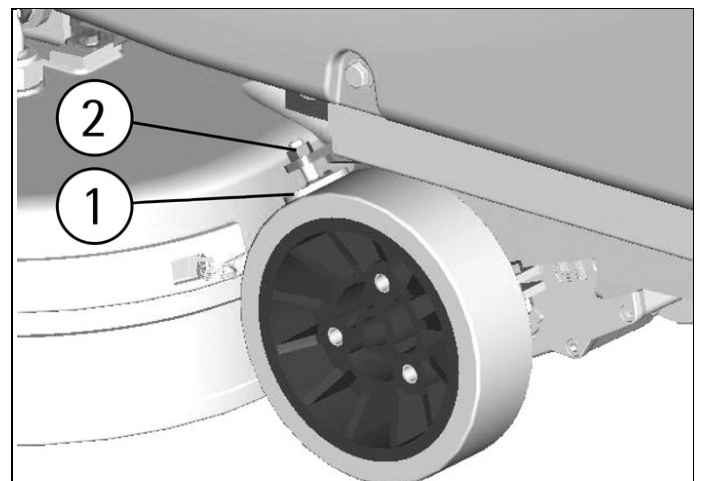



TROUBLESHOOTING GUIDE

The checking of all the other foreseen machine operations is left to the authorized technical assistance.

SIGNALS ON THE DISPLAY

A001: Indication of the version of the electronic check card (the last number indicates the revision of the check card).

Pb24: Indication battery check card set for lead batteries.

GE24: Indication battery check card set for gel batteries.

AL01: Signal indicating an absorption of excessive current of the brushes motor.

---- (blinking): signal indicating the discharged batteries and intervention of the brushes stop device.

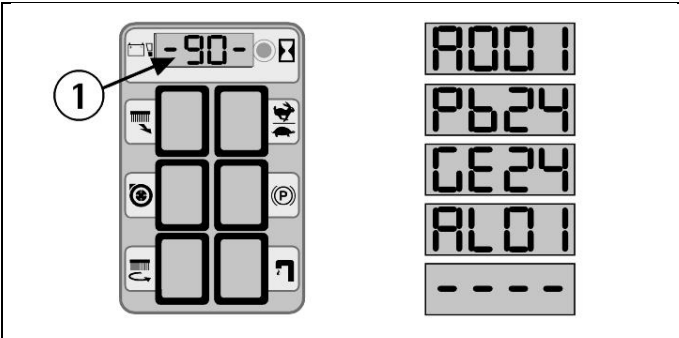

THE SUCTION MOTOR DOES NOT WORK

1. Verify that the key switch (8) is in the correct position.
2. Check the charge level of the batteries.

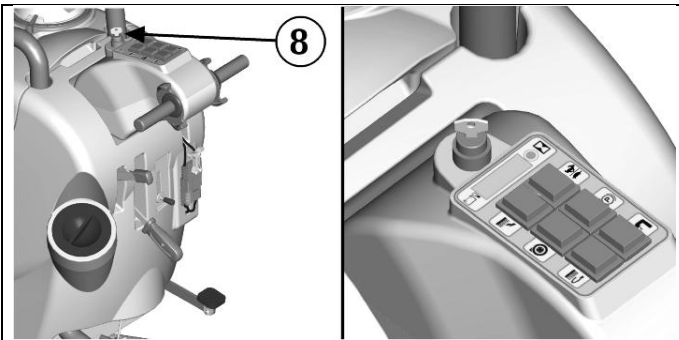

3. Check that the battery connector is correctly plugged in.
4. Verify that the switch (6) is on.

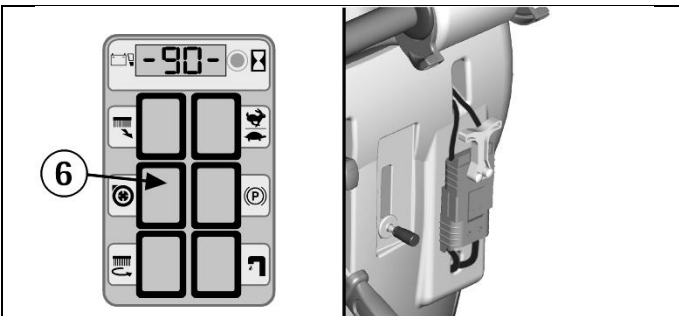

5. Check that the red connector of the suction motor (1) is correctly plugged in.
- If the problem persists, please contact the authorized technical assistance.

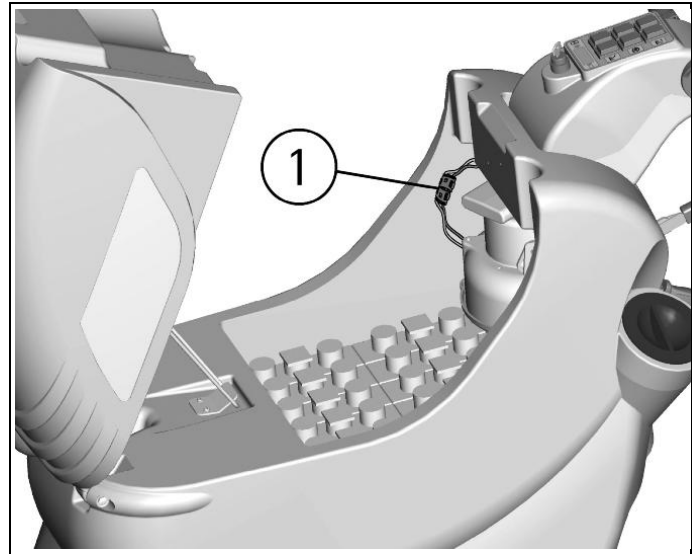

THE BRUSHES MOTOR DOES NOT WORK

1. Verify that the key switch (8) is in the correct position. Switch off and on again the machine.
2. Check the charge level of the batteries.
3. Check that the battery connector is correctly plugged in.
4. Verify that the switch (5) is on.
5. Act upon the levers drive control (9).
6. Check that on the display (1) does not appear the alarm "AL01" (brushes motor overload alarm).

If the problem persists, please contact the authorized technical assistance.

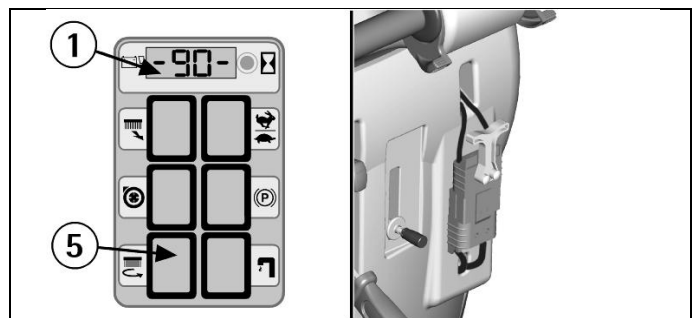
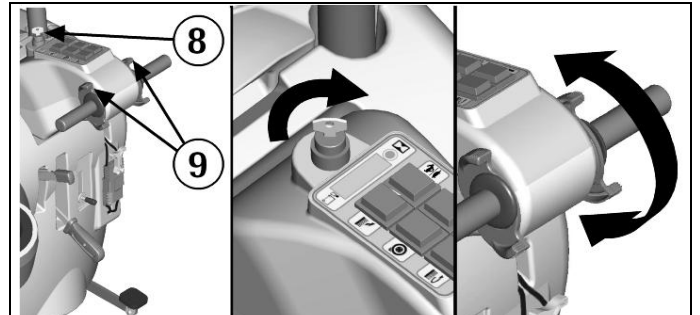

THE TRACTION MOTOR DOES NOT WORK

1. Switch off and on again the machine.
2. Release the brake (10) until the signal lamp (3) comes off.
3. Act upon the levers drive control.

If the problem persists, please contact the authorized technical assistance.

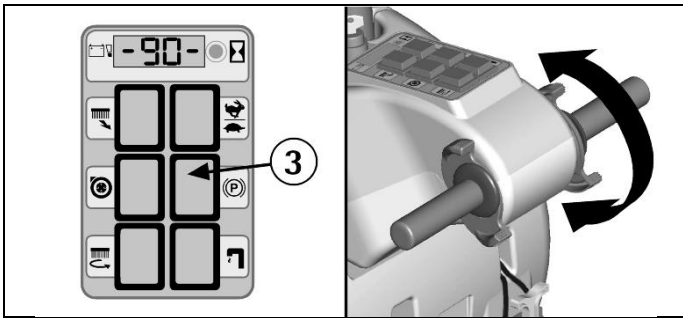
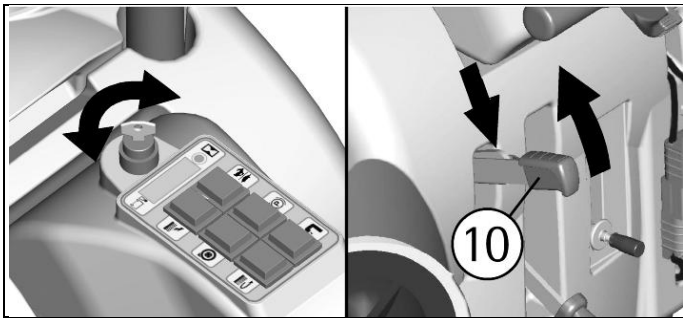

INSUFFICIENT WATER ON THE BRUSHES

1. Check that the solution valve lever (11) is open.
2. Check the level of the liquid in the solution tank.
3. Check that the solution filter (2) is clean.
4. The machine is equipped with solenoid valve, therefore act upon the levers drive control (9).
5. If the machine is equipped with the 3S system (see under "3S SYSTEM SOLUTION SAVING SYSTEM") (optional), check that the switch of the detergent solution supply is activated by choosing between the traditional adjustment system through the solution valve or the system of fixed optimum supply. Furthermore, verify that the filter of the auxiliary hydraulic circuit is clean.

If the problem persists, please contact the authorized technical assistance.

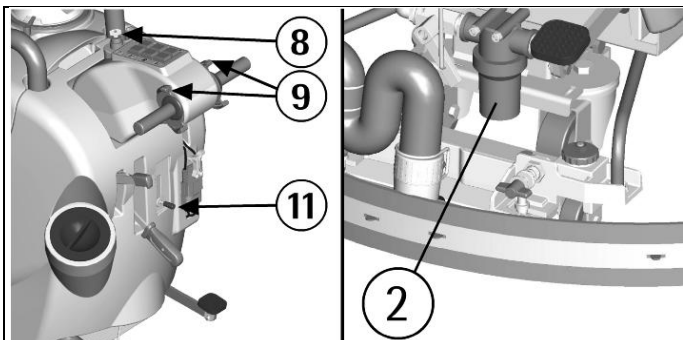

MACHINE DOES NOT CLEAN PROPERLY

1. The brushes do not have the suitable bristle dimension: contact the authorized technical assistance.
2. The brushes have got worn bristles. Check the brushes wear condition and eventually replace them (the brushes have to be replaced when the bristles have reached a height of about 15mm).
3. To replace the brushes, see instructions at paragraph "BRUSHES DISASSEMBLY" and "BRUSHES ASSEMBLY".
4. The solution detergent is insufficient: open more the solution valve.
5. Check that the liquid detergent is in the recommended percentage.
6. Increase the brushes base pressure (see at paragraph "ADJUSTMENT OF THE BRUSHES PRESSURE").

Contact the authorized technical assistance for advice.

THE SQUEEGEE DOES NOT DRY PERFECTLY

1. Check that the squeegee rubbers are clean.
2. Check the adjustment of the height and the inclination of the squeegee. (see section "ADJUSTMENT OF THE SQUEEGEE" in "BEFORE USE").

3. Check that the suction hose is correctly inserted in the proper seat on the recovery tank.
4. Clean the suction filter.
5. Replace the rubbers if worn out.
6. Check that the suction motor switch is on.

EXCESSIVE FOAM PRODUCTION

Check that low foam detergent has been used. Eventually add small quantities of anti foam liquid into the recovery tank.

Please be aware that a bigger quantity of foam is produced when the floor is not very dirty. In this case please dilute detergent solution.

PROGRAMMED MAINTENANCE

INTERVENTION	DAILY	PERIODIC
RECOVERY TANK CLEANING	•	
SUCTION FILTER CLEANING	•	
SOLUTION TANK FILTER CLEANING		•
BRUSHES CLEANING	•	
BRUSHES DISASSEMBLY AND CLEANING	•	
SQUEEGEE CLEANING	•	
FRONT SQUEEGEE RUBBER REPLACEMENT		•
REAR SQUEEGEE RUBBER REPLACEMENT		•
SPLASH GUARD RUBBER REPLACEMENT		•
CHECK SQUEEGEE ADJUSTMENT		•
SQUEEGEE HOSE CLEANING		•
SOLUTION TANK CLEANING		•
CHECK BATTERIES ELECTROLYTE		•
CHECK OF THE BRAKE		•
TRACTION MOTOR CHECK		•
BRUSHES MOTOR CHECK		•
SUCTION MOTOR CHECK		•
CHECK BRUSHES BASE GROUP		•



ADIATEK® Takarítógépek Magyarországi Képviselője

H-9700 Szombathely, Zanati út 26. Fsz. – Zanati 26 Irodaház

Telefon: +36 94 452 972, +36 70 409 2655

E-mail: info@takaritogepcentrum.hu

www.takaritogepcentrum.hu

www.adiatek.com