



diamond 100s AC

GYALOGKÍSÉRETŰ TAKARÍTÓGÉP

HASZNÁLATI ÉS KARBANTARTÁSI ÚTMUTATÓ

EN

diamond 100s

07 2015



Use and maintenance



Attention! Please read the instructions before use.

SUMMARY

LEGEND PANEL OF CONTROLS	4	Working in manual mode	11
LEGEND MACHINE	4	Side brush	12
TECHNICAL DESCRIPTION	5	Working adjustments	12
INTRODUCTORY COMMENT	5	Flow adjustment of the detergent solution	12
GENERAL RULES OF SECURITY	5	Adjustment of the brushes pressure	12
SYMBOLOLOGY	6	Electric protection	12
OPTIONAL ACCESSORIES	6	Overflow device	12
BEFORE USE	7	STOP OF THE MACHINE AFTER CLEANING OPERATION	13
Handling of the packed machine	7	DAILY MAINTENANCE	13
Unpacking of the machine	7	Recovery tank emptying and cleaning	13
Access to the battery compartment	7	Emptying and cleaning of the collection box	13
Battery installation and setting of the battery type	7	Suction filter cleaning	14
Assembling of the rollbar	7	Brushes cleaning	14
Battery recharger	7	Squeegee cleaning	14
Batteries recharging	7	WEEKLY MAINTENANCE	14
Batteries disposal	7	Rear squeegee rubber check	14
Connection battery connector and switching on of the machine	7	Check of the side rubbers	14
Batteries charge level indicator	7	Squeegee hose cleaning	14
Hour meter	8	Cleaning of the solution tank and of the outer filter	14
Squeegee assembly	8	TWO-MONTHLY MAINTENANCE	15
Adjustment of the squeegee	8	Front squeegee rubber check	15
Adjustment side rubbers	8	SIX-MONTHLY MAINTENANCE	15
Brushes assembly and disassembly	8	Splash guard rubber check of the side brush	15
Side brush assembly and disassembly	9	Check of the brakes	15
FLOOR CLEANING	9	TROUBLESHOOTING GUIDE	15
Recovery tank	9	The suction motor does not work	15
Detergent solution tank	10	The brushes motor does not work	15
STARTING OF THE MACHINE	10	The traction motor does not work	15
Forward and backward movement	10	The water does not come down onto the brushes or is insufficient	16
Horn	10	The machine does not clean properly	16
Working brake	10	The squeegee does not dry perfectly	16
Emergency-parking brake	11	Excessive foam production	16
Automatism squeegee lifting when going backwards	11	PROGRAMMED MAINTENANCE	17
Working in automatic mode	11	RECOMMENDED BRUSHES	17

LEGEND PANEL OF CONTROLS

- | | |
|--|--|
| <ol style="list-style-type: none"> 1. DISPLAY VISUALIZATION 2. PUSH BUTTON VISUALIZATION HOUR METER (DISPLAY) 3. PUSH BUTTON VISUALIZATION BRUSHES PRESSURE SET (DISPLAY) 4. ADJUSTMENT SELECTOR BRUSHES PRESSURE 5. KEY SWITCH 6. PUSH BUTTON HORN 7. CONTROL PANEL FUNCTIONS 8. SELECTOR FORWARDS/BACKWARDS 9. SELECTOR SPEED 10. SOLUTION VALVE LEVER 11. SWITCH WATER OPENING (SOLENOID VALVE) 12. SELECTOR MODE OF FUNCTIONING 13. SWITCH SIDE BRUSH ACTIVATED | <ol style="list-style-type: none"> 14. SELECTOR UP/DOWN BRUSHES 15. SELECTOR UP/DOWN SQUEEGEE 16. SWITCH SUCTION MOTORS 17. SIGNAL LAMP PARKING BRAKE ON 18. SIGNAL LAMP SUCTION MOTORS ON 19. SIGNAL LAMP DETERGENT SOLUTION LOW 20. SIGNAL LAMP RECOVERY TANK FULL 21. SIGNAL LAMP SQUEEGEE DOWN 22. SIGNAL LAMP BRUSHES DOWN 23. SIGNAL LAMP BRUSHES ROTATION 24. SIGNAL LAMP WATER OPEN (SOLENOID VALVE) 25. SIGNAL LAMP SIDE BRUSH ACTIVATED 26. SIGNAL LAMP RESTORATION LIQUID LEVEL BRAKES |
|--|--|

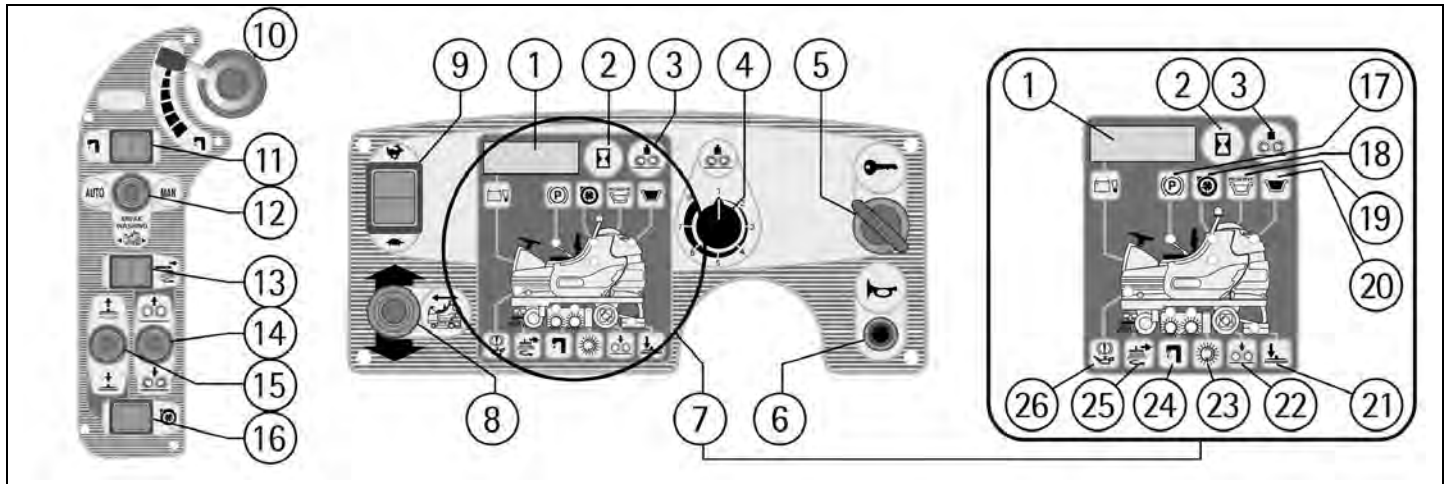

LEGEND MACHINE

- | | |
|---|---|
| <ol style="list-style-type: none"> 1. RECOVERY TANK 2. SOLUTION TANK 3. SEAT 4. DRIVE WHEEL 5. SCREW CAP FOR INLET DETERGENT SOLUTION 6. BLINKING LIGHT 7. ROLLBAR 8. INSPECTION CAP RECOVERY TANK 9. SQUEEGEE HOSE 10. PLUG EXHAUST HOSE RECOVERY TANK | <ol style="list-style-type: none"> 11. EXHAUST HOSE RECOVERY TANK 12. SQUEEGEE ASSEMBLY 13. PANEL CONTROLS 14. LEVER BLOCK/RELEASE PARKING BRAKE 15. COVER ELECTRICAL LAYOUT 16. BUMPER 17. PEDAL ACCELERATOR 18. TRACTION MOTOR WHEEL 19. SIDE BRUSH 20. BOTTOM PLATE 21. BRUSHES BASE GROUP 22. REAR WHEELS |
|---|---|

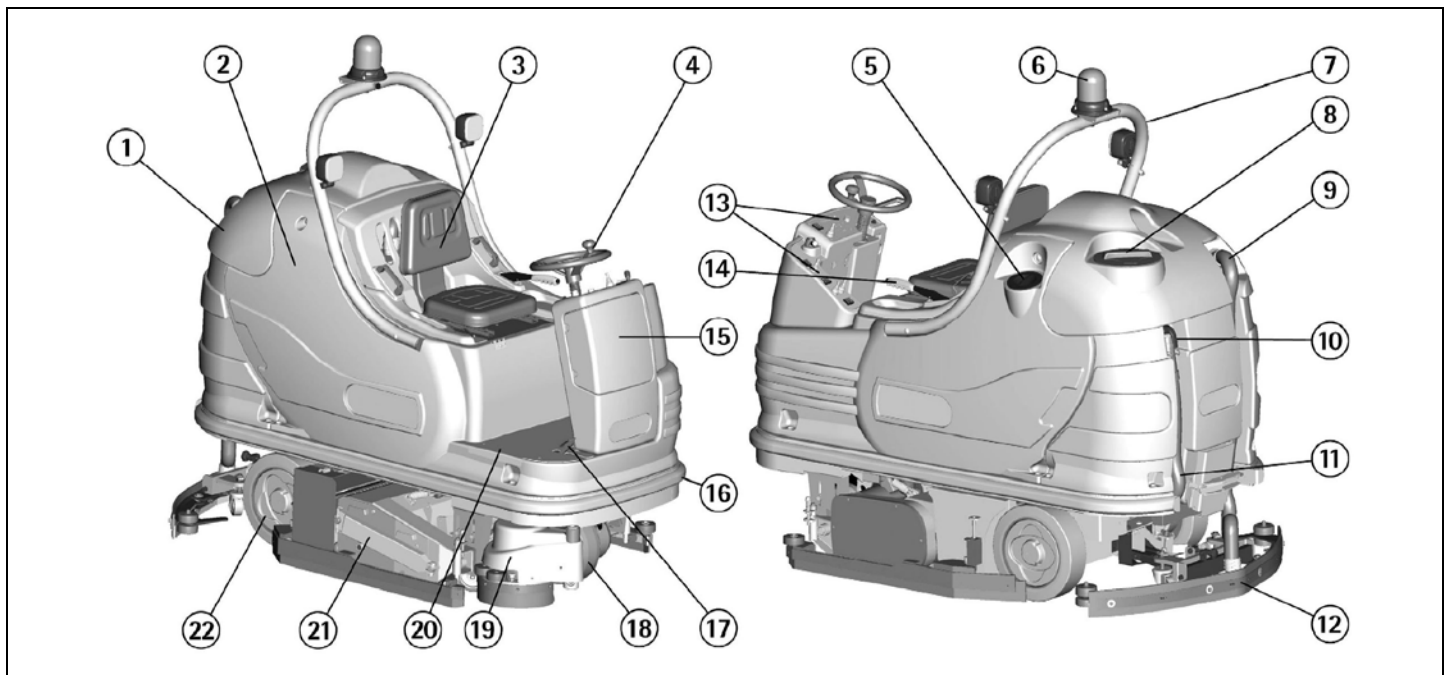

TECHNICAL DESCRIPTION	U/M	diamond 100s
Cleaning width	mm	1000
Squeegee width	mm	1300
Working capacity, up to	sqm/h	7000
Diameter front cylindrical brush	mm	150
Diameter rear cylindrical brush	mm	280
Diameter side brush	mm	285
Front brush rpm	rpm	933
Rear brush rpm	rpm	500
Side brush rpm	rpm	200
Pressure on the cylindrical brushes	kg	110 max
Pressure on the side brush	kg	35
Brushes motor	W	1800
Motor side brush	W	150
Traction motor	W	1200
Suction motors	W	2x570
Suction vacuum	mbar	190
Type of drive		autom.
Movement speed I-II	km/h	4.5-7,0
Maximum gradient	%	10
Solution tank	l	235
Recovery tank	l	250
Machine length	mm	2025
Machine height (without rollbar)	mm	1330
Machine height (with rollbar and without blinking light)	mm	1795
Machine height (with rollbar and blinking light)	mm	1965
Machine width (without squeegee)	mm	1165
Machine width with side brush in operating position	mm	1250
Weight of the machine (empty and without batteries)	kg	670
Capacity of the batteries	Ah _s	500
Weight of the batteries	kg	600
Compartment of the batteries	mm	655x640x530
Acoustic pressure level (in conformity with EN 60704-1)	dB (A)	---
Class		III
Protection level	IP	X3
Tension	V	36

INTRODUCTORY COMMENT

Thank you for having chosen our machine. This floor cleaning machine is used for the industrial and civil cleaning and is able to clean any type of floor. During its advance movement, the combined action of the brushes and the detergent solution removes the dirt which is aspirated through the rear suction assembly, giving a perfectly dry surface.

The machine must be used only for such purpose. It gives the best performance if it is used correctly and maintained in perfect efficiency. We therefore ask you to read this instruction booklet carefully whenever difficulties arise in the course of the machine's use. In case of need, we ask you to contact our service department for all advice and servicing as may prove necessary.

GENERAL RULES OF SECURITY

The rules below have to be followed carefully in order to avoid damages to the operator and to the machine.

- Read the labels carefully on the machine. Do not cover them for any reason and replace them immediately if damaged.
- The machine must be used exclusively by authorized staff that has been instructed for its use.
- During the working of the machine, pay attention to other people and especially to the children.
- In case of danger act immediately upon the emergency brake.
- Leaving the machine in parking position, take off the key and act upon the parking brake.

- Do not mix different detergents, avoiding harmful odours.
- Storage temperature: between -25°C and +55°C.
- Perfect operating temperature: between 0°C and 40°C.
- The humidity should be between 30 and 95%.
- Do not use the machine in explosive atmosphere.
- Do not use acid solutions which could damage the machine and/or the persons.
- Do not use the machine on surfaces covered with inflammable liquids or dusts (for example hydrocarbons, ashes or soot).
- In case of fire, use a powder fire-extinguisher. Do not use water.
- Do not strike shelvings or scaffoldings, where there is danger of falling objects.
- Adapt the working speed to the adhesion conditions: particularly, slow down before narrow curves have to be faced.
- Do not use the machine on areas having a higher gradient than the one stated on the number plate.
- The machine has to carry out simultaneously the operations of washing and drying. Different operations must be carried out in restricted areas prohibited to non-authorized personnel. Signal the areas of moist floors with suitable signs.
- If the machine does not work properly, check by conducting simple maintenance procedures. Otherwise, ask for technical advice an authorized assistance centre.
- Where parts are required, ask for ORIGINAL spare parts to an authorized dealer.
- Use only ORIGINAL brushes indicated in the paragraph "RECOMMENDED BRUSHES".

- For any cleaning and/or maintenance operation take off the power supply from the machine.
- Do not take off the protections which require the use of tools to be removed.
- Do not wash the machine with direct water jets or with high water pressure nor with corrosive material.
- Every 200 working hours have a machine check through an authorized service department.
- In order to avoid scales on the solution tank filter, do not fill the detergent solution many hours before the machines' use.
- Before using the machine, check that all panels and coverings are in their position as indicated in this use and maintenance catalogue.
- Restore all electrical connections after any maintenance operation.
- Provide for the scrapping of the material of normal wear following strictly the respective rules.
- When, your machine has to stop activity, provide for the appropriate waste disposal of its materials, especially oils, batteries and electronic components, and considering that the machine itself has, where possible, been constructed using recyclable materials.

SYMBOLOLOGY



Symbol denoting the switch for the water opening and the signal lamp that the water is open.

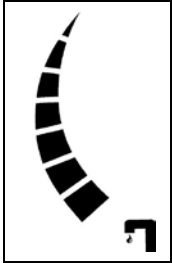

Symbol denoting the functioning of the solution valve adjusting the flow of the detergent solution.



Indication of the maximum temperature of the detergent solution. It is placed near the charging hole of the solution tank.



Symbol denoting the selection of the operation mode in manual.



Symbol denoting the selection of the operation mode in automatic.



Symbol denoting the selection of the mode at the end of the washing and transfer.

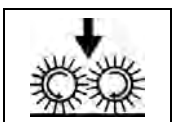

Symbol denoting the activation and the signal lamp brushes down.

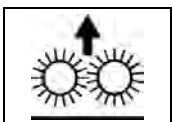

Symbol denoting the activation of the brushes up.

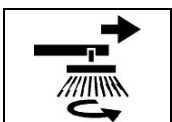

Symbol denoting the activation and the signal lamp of the side brush.



Symbol denoting the signal lamp of the brushes rotation.

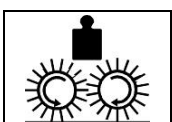

Symbol denoting the push button to visualize on the display the brushes pressure set.

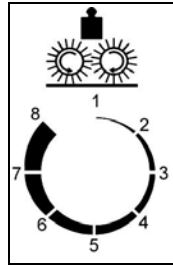

Symbol denoting the functioning of the adjustment selector of the brushes pressure.

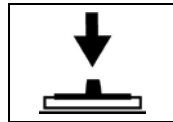

Symbol denoting the activation and the signal lamp squeegee down.

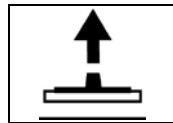

Symbol denoting the activation of the squeegee up.



Symbol denoting the switch and the signal lamp of the functioning of the suction motors.

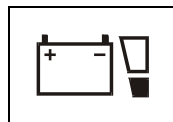

Symbol denoting the charge level of the batteries.



Symbol denoting the push button to visualize the hour meter on the display.

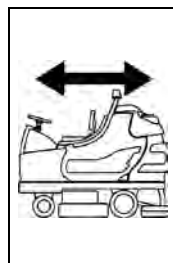

Symbol denoting the selection of the forward/backward movement.

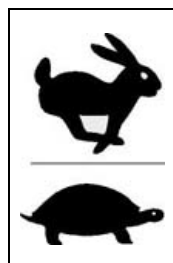

Symbol denoting the selection switch of the operation speed.



Symbol denoting the signal lamp of the parking brake on.



Symbol denoting the key switch.

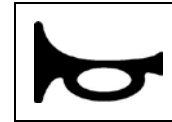

Symbol denoting the push button of the horn.



Symbol denoting the signal lamp of low detergent solution.



Symbol denoting the signal lamp of overflow of the recovery tank.



Symbol denoting the signal lamp of restoration level liquid brakes.



Symbol denoting the open book. Indicates that the operator has to read the manual before the use of the machine.



Warning symbol. Read carefully the sections marked with this symbol, for the security of both the operator and the machine.

OPTIONAL ACCESSORIES



Movable working lights



Rollbar lowered of 120 mm

BEFORE USE

HANDLING OF THE PACKED MACHINE

The machine is supplied with suitable packing foreseen for fork lift truck handling.

The total weight is 720 kg.

Packing dimensions:

Base: 213 cm x 125 cm

Height: 165 cm



ATTENTION:

Do not place any packings on top.

UNPACKING OF THE MACHINE

1. Remove the external packing.
2. Move the machine backwards, as indicated in the figure, avoiding heavy contacts to mechanical parts.

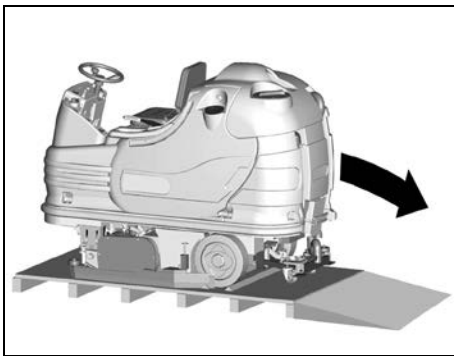

3. Keep the pallet for eventual transport.

ACCESS TO THE BATTERY COMPARTMENT

1. Bring the machine on a levelled surface.
2. Rotate the seat platform forward up to the blocking of the support.
3. Having finished any intervention, to close the battery compartment, after having released the support, reposition the seat platform.

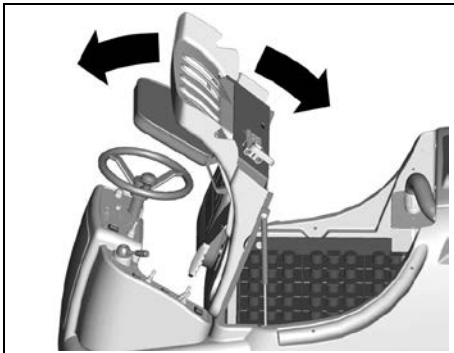

BATTERY INSTALLATION AND SETTING OF THE BATTERY TYPE

The machine is equipped either with batteries in serial connection or elements of DIN-type assembled together and connected in series for a total of 36 Volt, placed in its appropriate compartment under the seat platform and must be handled using suitable lifting equipment (due to weight, considering the type of batteries chosen, and coupling system). The batteries must be in accordance with CEI 21-5 Norms.



ATTENTION:

The machine and its battery check card foresee the use of traditional lead batteries.

CHECK THE SETTING OF THE CHECK CARD (see under paragraph "BATTERIES CHARGE LEVEL INDICATOR").

In case of GEL batteries installation, it is necessary to set the battery check card. Please contact the authorized technical assistance.



ATTENTION:

Strictly follow manufacturer/distributor indications for the maintenance and recharge of the batteries. All installation and maintenance operations must be executed by specialized staff, using suitable protection accessories.

For batteries installation it is necessary to reach the battery compartment as indicated under paragraph "ACCESS TO THE BATTERY COMPARTMENT".

1. Place the batteries in its compartment.
2. **Connect the terminals, respecting the polarities, avoiding contact with other parts that could create short circuit.**

ASSEMBLING OF THE ROLLBAR

For packing reasons the support of the blinking light is supplied disassembled.

Proceed as follows:

1. Take off the four fixing screws (1) from the rollbar.
2. Place the rollbar into their seats (2) on the tank.
3. Fasten the screws passing them in the same order in their holes foreseen on the support.
4. Complete the assembly connecting the connectors (3) to supply the blinking light and the working lights (optional).

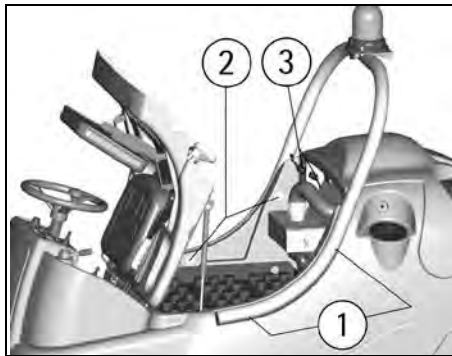

BATTERY RECHARGER

Make sure that the battery recharger is suitable for the installed batteries both for their capacities and type (lead/acid or GEL and equivalent).

In the plastic bag containing the use and maintenance you will find the coupling connector for the recharger. It must be assembled onto the cables of your recharger, following the instructions given by the manufacturer.



ATTENTION:

This operation must be carried out by qualified staff. A wrong or faulty cable connection can cause serious damages to persons or things.

BATTERIES RECHARGING

1. Plug the connector (3) of the battery recharger into the battery connector.
2. Proceed for the recharging.



ATTENTION:

Never charge a GEL battery with a non suitable recharger. Strictly follow the instructions supplied by the batteries and recharger manufacturer.

In order not to cause permanent damages to the batteries, it is necessary to avoid their complete discharge, providing for the recharging within a few minutes after that the batteries discharge signal starts blinking.

NOTE: Never leave the batteries completely discharged even if the machine is not used. In case of traditional batteries, please check the electrolyte level every 20 recharging cycles and eventually top them up with distilled water. Never leave the batteries discharged for more than two weeks.



ATTENTION:

For the recharge of the batteries it is necessary to follow strictly all the indications given by the manufacturer/distributor. All the installation and maintenance operations must be carried out by qualified staff. **Danger of gas exhalations and emission of corrosive liquids. Fire danger: do not approach with free flames.**

BATTERIES DISPOSAL

It is compulsory to hand over exhausted batteries, classified as dangerous waste, to an authorized institution according to the current laws.

CONNECTION BATTERY CONNECTOR AND SWITCHING ON OF THE MACHINE

Once that the battery recharging has been completed:

1. Disconnect the connector of the battery recharger from the battery connector (1).
2. Connect then the battery connector (1) to the machine connector (2).

To start any function of the machine, it is necessary to rotate clockwise the key switch (5). Rotating it counterclockwise any function will be switched off.

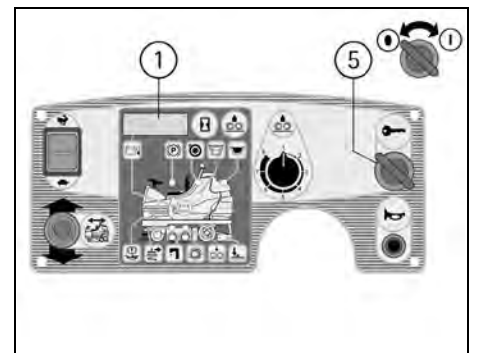

BATTERIES CHARGE LEVEL INDICATOR

WHEN THE MACHINE IS SWITCHED ON, ON THE DISPLAY (1) APPEAR IN ORDER THE FOLLOWING INFORMATION:

1. the version (for example A003) of software installed on the machine.
2. the setting of the battery check card which can be:
GE 36: check card set for GEL batteries.
or
Pb 36: check card set for lead batteries.

3. The batteries charge level indicator is digital and remains fixed on the display. The battery charge level starts from 100, which indicates the 100% of the total charge and decreases from 10 to 10. When the charge level reaches 20%, the display starts blinking, so you are about the end of working.

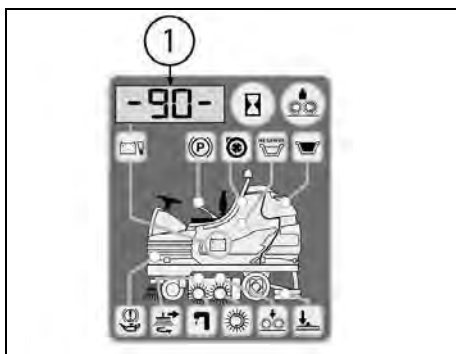
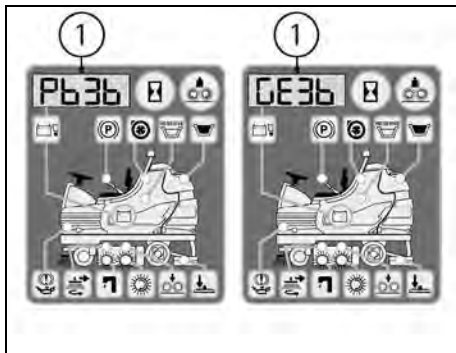
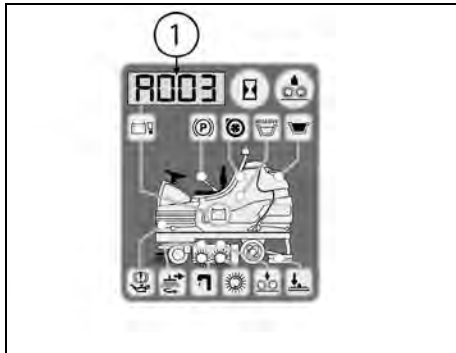

⚠ ATTENTION:

After a few seconds of the indication 10% and after this, the blinking of the four lines, all the functions stop automatically. With the remaining charge it is anyhow possible to finish the drying operation before proceeding to the recharge.

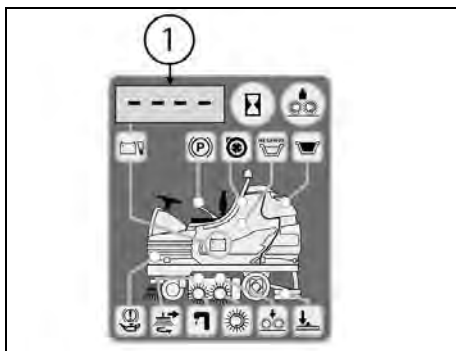

HOUR METER

The machine is equipped with an hour meter located on the same display (1) of the battery charge level indicator. Pressing the button (2), the first data indicates the working hours and after a few seconds the working minutes are shown.

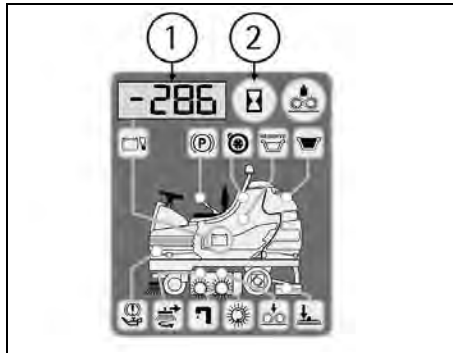

SQUEEGEE ASSEMBLY

1. Insert the two screws (3) situated on the upper part of the squeegee (2) inside the slots present on the support.
2. To block the squeegee tighten the stud bolts (3).
3. Insert the squeegee hose (4) into its coupling, respecting its position as indicated in the figure.

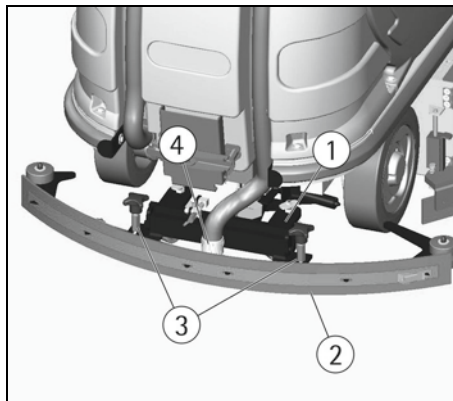

ADJUSTMENT OF THE SQUEEGEE

In order to have a perfect drying result through the squeegee, the rear rubber must have the lower bending uniformly adjusted in all its length. For the adjustment, it is necessary to put oneself in working condition and therefore the suction motor has to be switched on and the brushes have to function together with the detergent solution.

The lower part of the rubber is too much bent

Take off the pressure rotating the wing nut (5) counterclockwise.

The lower part of the rubber is not much bent

Increase the pressure rotating the wing nut (5) clockwise. Check that the wheels which adjust the height do not rest on the floor, in this case adjust them as indicated in paragraph "Height adjustment".

The bending is not uniform

Adjust the squeegee inclination rotating counterclockwise the wing nut (6) to increase the bending in the central part, or clockwise to increase the bending on the extremities.

Height adjustment

Once that the pressure and inclination of the squeegee have been adjusted, it is necessary to fix this optimum condition making touch slightly the wheels onto the floor. Rotate clockwise the registers (7) to lower the wheels or counterclockwise to raise them. Both wheels must be adjusted in the same measure. To act upon the register (7) loosen at the same time the two milled ring nuts, adjust the height acting on the upper one and then fix the adjustment screwing and blocking the lower one.

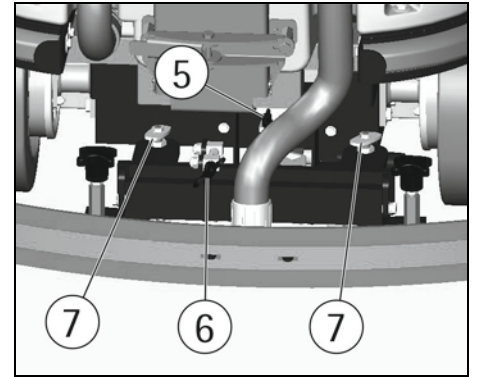

⚠ ATTENTION:

Every type of floor requires a specific adjustment. For example, concrete floors (where the friction results to be high) need little pressure, while smooth floors (ceramics) need higher pressure.

If the cleaning operations are made always on the same type of floor, the adjustment can change only in function of the rubber wear.

ADJUSTMENT SIDE RUBBERS

To adjust the side rubbers, it is necessary to act upon the knob (1). Screwing down, more pressure is given and unscrewing, pressure is being taken off. The reason of the adjustment is to obtain an uniform rubber bending.

NOTE: If the rubber should lower in the rear part, it is necessary to restore the correct bending by acting upon the screw (2).

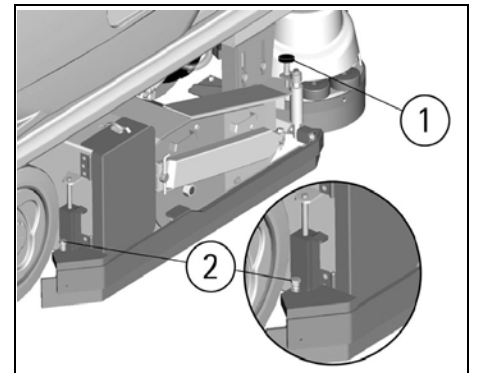

BRUSHES ASSEMBLY AND DISASSEMBLY

Normally, the machine is delivered with the brushes assembled.

To assemble and disassemble the brushes:

1. Position the selector (4) for the adjustment of the brushes pressure on position P1.
2. Activate the machine (see under paragraph "STARTING OF THE MACHINE") positioning the selector (12) to the right to choose the manual mode (MAN).
3. Activate the selector (14) of up/down of the brushes base to lower the brushes. Once that it is lowered, the brushes begin to turn.
4. Turn the key counterclockwise to turn off the machine.

⚠ ATTENTION:

To carry out brushes assembly operations with the electric supply on, may cause damages to hands.

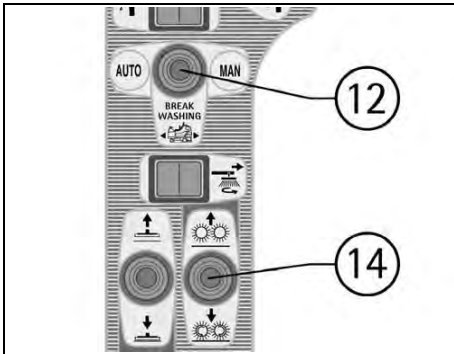
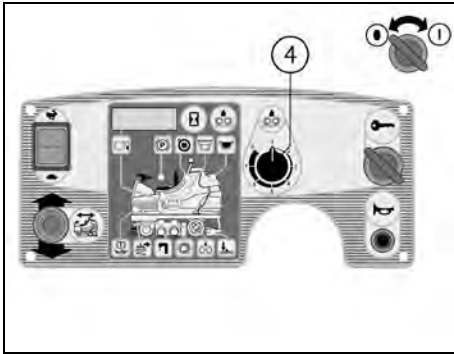

⚠ ATTENTION:

This operation must be carried out using gloves to protect from contact with dangerous solutions.

5. Open the bar of the right side rubber after having released it pulling the stop (1) upwards.

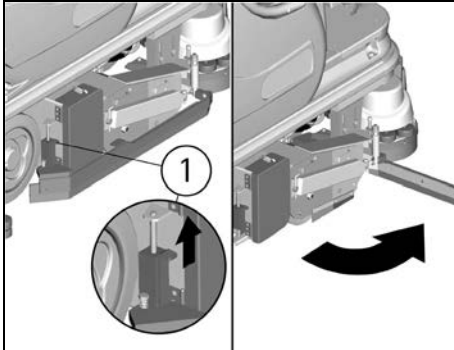

6. Take off the stop (2) then unscrew and take off the knob so to open the blocking support as shown in the figure.

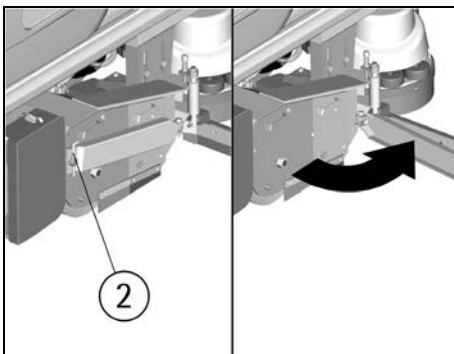

7. Extract the support plates (3) and (4) of the brushes pulling them outwards by holding their handles.

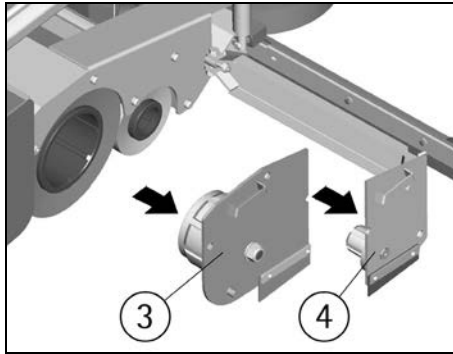

8. Extract the rear brush (5) and the front brush (6).

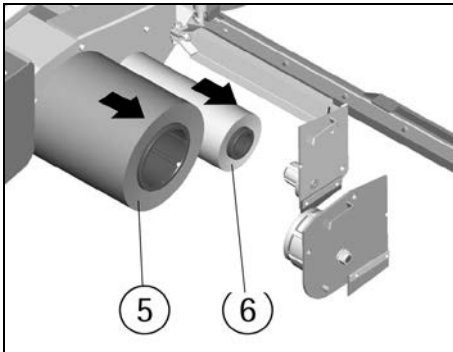

9. When reassembling the rear brush (5) pay attention to the bristles design, so that it will be assembled always in the same direction as shown in the figure.

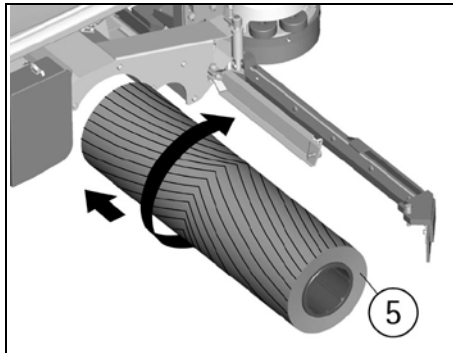

10. During the reassembly of the brush (6), insert it into the brush base from the part where the seat is deeper (about 40mm). The opposite part with a depth of about 13,5mm has to look towards the support plate.

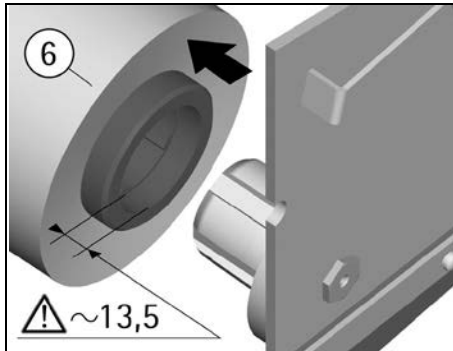

11. Place the support plates (3) and (4) into their position, then the blocking support, screw down the knob and insert once more the stop (2) and finally re-position and block the bar of the side rubber through the stop (1).

⚠ ATTENTION:

The brushes must be inserted easily without using tools in order not to damage or force them. Use only brushes supplied with the machine or the ones indicated in the paragraph "RECOMMENDED BRUSHES". The use of other brushes can compromise the good washing result.

SIDE BRUSH ASSEMBLY AND DISASSEMBLY

The machine is equipped with a side brush that permits to clean near the right side borders. To assemble the brush, the device has to be in rest position at machine stop.

⚠ ATTENTION:

To carry out brushes assembly operations with the electric supply on, may cause damages to hands.

⚠ ATTENTION:

This operation must be carried out using gloves to protect from contact with dangerous solutions.

1. Keep the push button (1) pressed that blocks the rotation of the brush plate.
2. Insert the brush into its plate seat underneath the brush base turning it until the three metal buttons are properly seated in their slots; rotate energetically the brush to push the button towards the coupling spring until it gets blocked. The figure shows the rotating sense for the brush coupling. For its release, rotate the other way round.

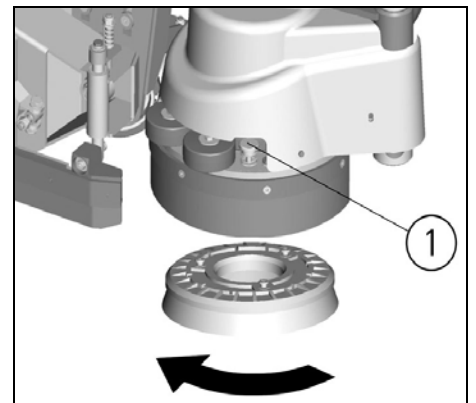

FLOOR CLEANING

RECOVERY TANK

Verify that the squeegee hose couplings (1/2) are correctly inserted into their seats and that the exhaust hose plug (4) placed in the rear part of the machine is well closed.

Check that the inspection cap (3) placed on the upper part of the tank is well closed.

Finally, verify the correct tightening of the closing lever (5) of the cleaning door (6) placed in the lower part of the tank.

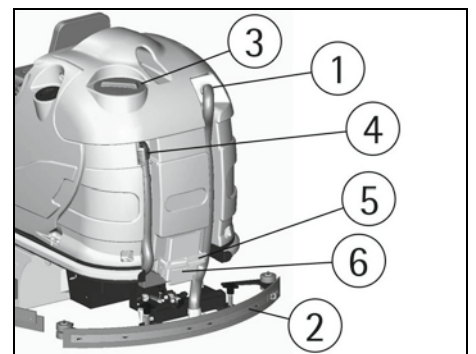

DETERGENT SOLUTION TANK

The capacity of the detergent solution tank is indicated in the technical data.

Open the screw plug placed in the left part of the machine and fill the detergent solution tank with clean water at a maximum temperature of 50°C. Add the liquid detergent in the percentage and conditions foreseen by the manufacturer. To avoid excessive foam presence, which could cause problems to the suction motors, use the minimum percentage of detergent. Screw down the plug to close the solution tank.

The switching on of the signal lamp of low detergent (19) indicates that the detergent solution is nearly exhausted.

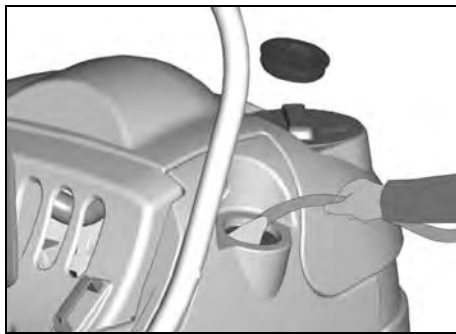
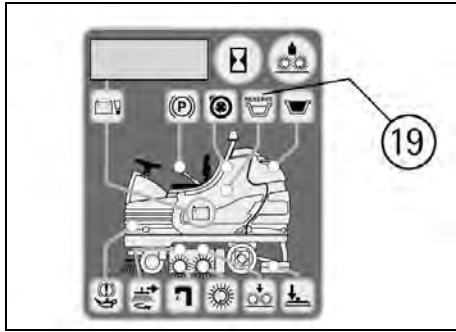

⚠ ATTENTION:

Use always low foam detergent. To avoid foam presence, before starting working operation, introduce into the recovery tank a minimum quantity of anti-foam product.

Never use pure acid.

STARTING OF THE MACHINE

A safety device avoids the machine's movement if the operator is not seated correctly on the guiding place.

To switch on the machine:

1. Sit on the guiding place.
2. Turn the key switch (5) clockwise to switch on the machine.
3. Check the charge level of the batteries on the display (1).
4. With the selector (12) in central position (BREAK WASHING) the transfer operations of the machine are carried out (see under paragraph "FORWARD AND BACKWARD MOVEMENT").
5. Moving the selector (12) onto the left, the automatic (AUTO) functioning is chosen. Moving it instead onto the right, the functioning of the machine becomes manual (MAN):

A. If the selector (12) is in position (AUTO) the machine activates and deactivates all the working functions in an automatic mode (see under paragraph "WORKING IN AUTOMATIC MODE").

B. If the selector (12) is in position (MAN) every function of the machine has to be activated or deactivated manually (see under paragraph "WORKING IN MANUAL MODE").

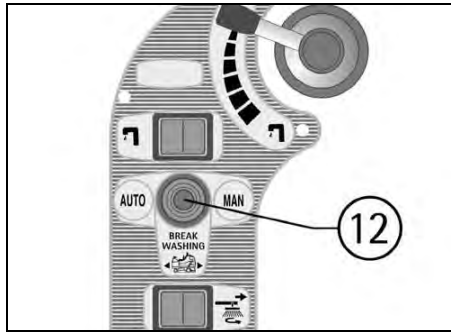
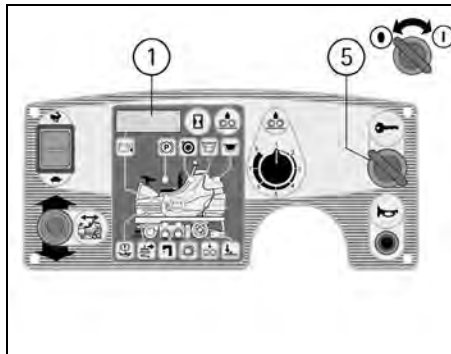

FORWARD AND BACKWARD MOVEMENT

It is recommendable to carry out always the mere transfer of the machine in mode (BREAK WASHING).

To proceed to activate the movement of the machine:

1. Sit on the guiding place.
2. Turn the key switch (5) clockwise to switch on the machine.
3. Check the charge level of the batteries on the display (1).
4. Release the parking brake. If the brake was inserted, the signal lamp (17) would be switched on (see under paragraph "EMERGENCY-PARKING BRAKE").
5. Bring the selector (12) in central position (BREAK WASHING) to carry out the mere transfer of the machine. In fact, in this mode the washing functions of the machine are not working and only the traction system functions.
6. Select the driving sense with the selector (8).
7. Press onto the accelerator pedal placed on the right side to start the machine.
8. Adjust the driving speed in forward choosing the slow one (at the maximum you can reach 4,5 km/h) or, pressing the same selector (9) upwards, the faster one (at the maximum you can reach 7 km/h) can be obtained.

In backward movement, when the machine is moving, an intermittent warning device is activated.

9. The machine is equipped with an automatic system that reduces the speed when the drive direction is changed. The speed reduction is as higher as sharper is the curve.

The speed returns again normally as soon as the machine gets out from the curve and it runs along straight paths.

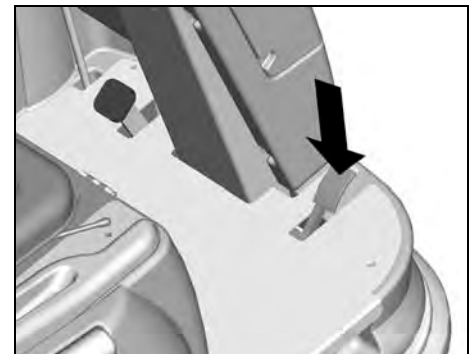
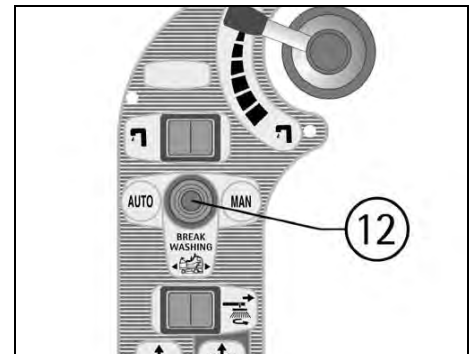
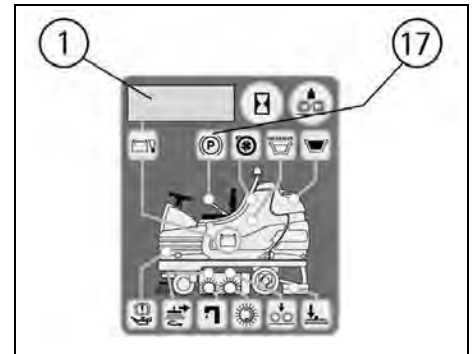
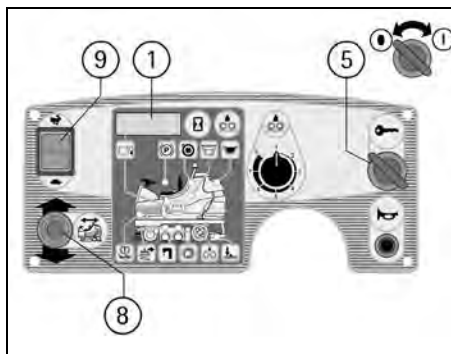

HORN

The machine is equipped with a horn which is activated pressing the push button (6).

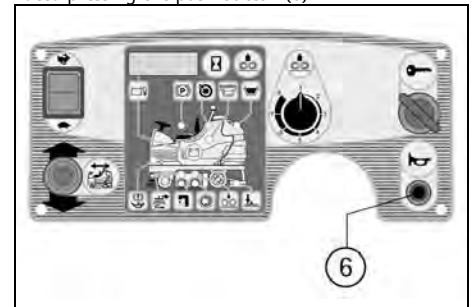

WORKING BRAKE

The machine is equipped with a hydraulic braking system that acts on the rear wheels.

To brake it is sufficient to press the pedal placed at the left side of the steering column releasing instead the accelerator pedal.

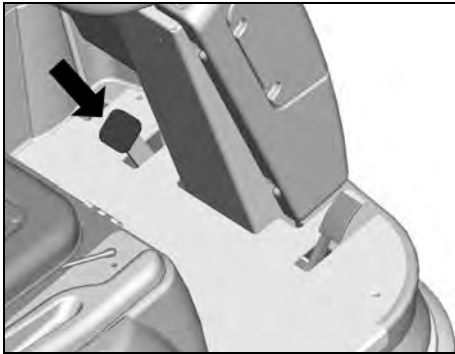

EMERGENCY-PARKING BRAKE

In case of an emergency pull the lever of the emergency and parking brake (1) placed on the left side of the seat.

On the instrument board the signal lamp (17) comes on which signals that the parking brake is inserted. To release the parking brake press the button (2) placed at the final part of the brake lever (1) and simultaneously lower it to the end.

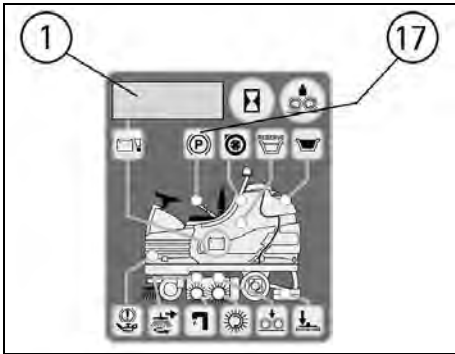
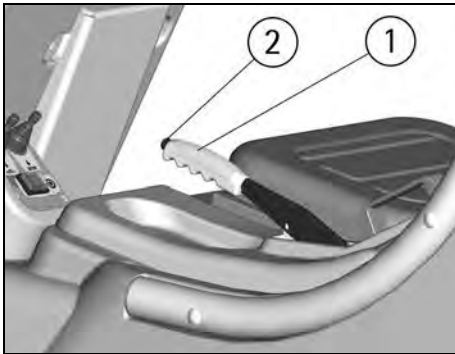

AUTOMATISM SQUEEGEE LIFTING WHEN GOING BACKWARDS

Selecting the backwards movement the squeegee is brought automatically to the upper position. It will then lower again in the following forward movement.

This happens both in automatic as in manual mode in order to protect the integrity of the squeegee.

WORKING IN AUTOMATIC MODE

The automatic operation is useful to simplify the operator's work.

1. Activate the machine (see under paragraph "STARTING OF THE MACHINE") putting the selector (12) into the left position to choose the automatic function (AUTO).

2. Check that the lever (10) is in the position of optimum flow, depending on the type of floor and the type of dirt (see under the paragraph "FLOW ADJUSTMENT OF THE DETERGENT SOLUTION").

3. Selecting the sense of drive in forward with the selector (8), pressing the accelerator pedal and adjusting the speed of the forward movement with the selector (9), the machine starts to proceed and in au-

tomatic mode all the working functions are activated. In fact, automatically both the brushes base as the squeegee go down, the brushes begin to turn, the solenoid valve opens to permit the detergent solution to flow down onto the brushes and the suction system is activated to recover the dirty water from the floor.

Selecting the backward movement with the selector (8) the squeegee lifts automatically and will then return to lower itself during the next forward movement.

If the accelerator pedal is released for more than 3 seconds, automatically all the functions are switched off and both the brushes base as the squeegee are lifted.

Pressing again the pedal, the machine starts to move again and in automatic mode all the working functions are reactivated.

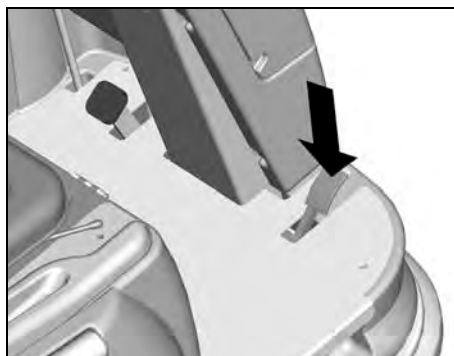
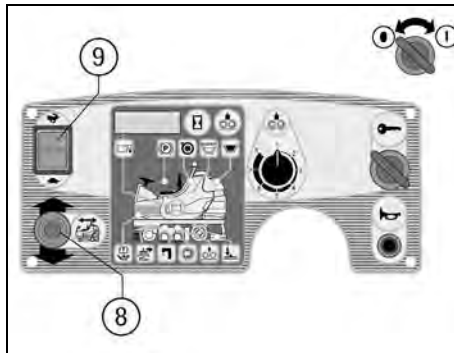
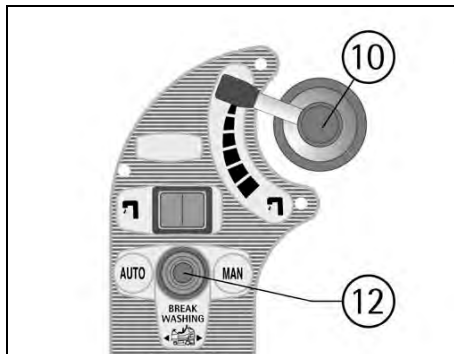

WORKING IN MANUAL MODE

The manual model is useful when, in special cases, it is necessary to carry out separately only the washing with the brushes or only the drying of the floor.

⚠ ATTENTION:

The washing and drying functions, when they are not carried out simultaneously, represent an improper use of the machine (see under paragraph "GENERAL RULES OF SECURITY"). If they are carried out separately, it is necessary to forbid the working areas to the passage of non-authorized personnel and to signal the areas of moist floors with suitable signs.

Activate the machine (see under paragraph "STARTING OF THE MACHINE") positioning the selector (12) to the right to choose the manual mode (MAN).

TO CARRY OUT THE WASHING WITH ONLY THE BRUSHES:

1. Activate the selector (14) of up/down of the brushes base to lower the brushes. Once that it is lowered, the brushes begin to turn. The signal lamp (22) indicates that the brushes base is in the working position, while the signal lamp (23) signals that the brushes are turning.

2. Press the switch (11) to open the solenoid valve and permit the detergent solution to lower onto the brushes. The signal lamp (24) will come on to indicate that the solenoid valve is open.

3. Check that the lever (10) is in the position of optimum flow, depending on the type of floor and the type of dirt (see under the paragraph "FLOW ADJUSTMENT OF THE DETERGENT SOLUTION").

TO CARRY OUT THE FUNCTION OF ONLY DRYING:

1. Activate the selector (15) of up/down squeegee to lower the squeegee. The signal lamp (21) indicates that the squeegee is in the working position.

2. Press the switch (16) of the suction motors to start the suction system. The signal lamp (18) indicates that the machine is drying.

Selecting the sense of drive in forward with the selector (8), pressing the accelerator pedal and adjusting the speed of the forward movement with the selector (9), the machine starts to proceed and in automatic mode all the working functions previously set are activated.



ATTENTION:

In manual mode every function of the machine has to be activated or deactivated manually.

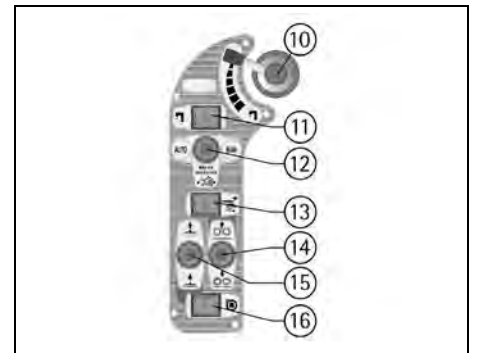
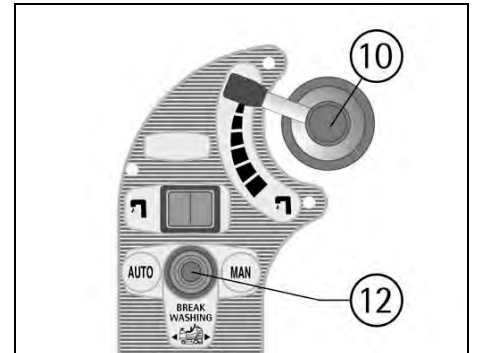

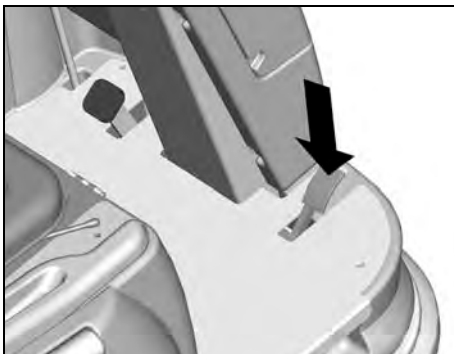
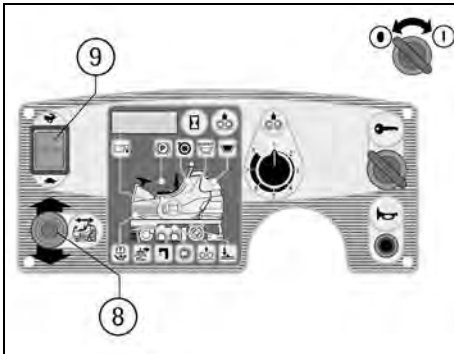
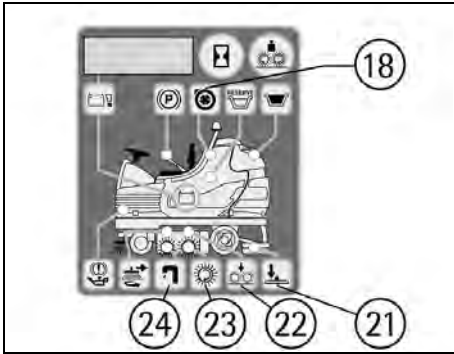

SIDE BRUSH

The machine is equipped with a side brush that permits to clean near the right side borders.

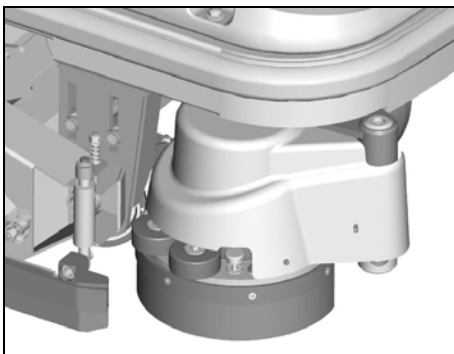

The function is activated acting upon the switch (13) both in manual as in automatic mode. The signal lamp (25) indicates that the side brush is active and in working position.

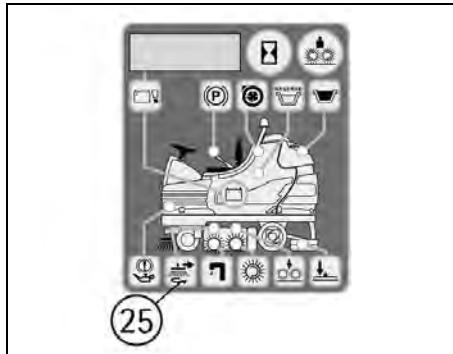
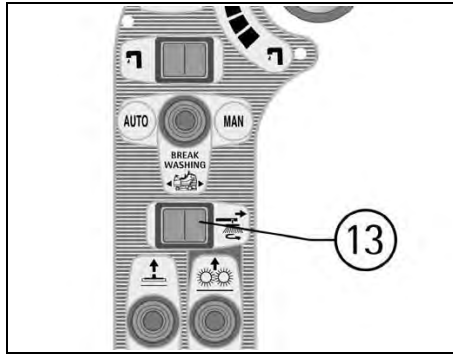

WORKING ADJUSTMENTS

Both in automatic as in manual mode, during the first metres check:

1. that the adjustment of the detergent solution flow is sufficient to wet the floor uniformly avoiding the leakage of detergent from the splash guards (see under paragraph "FLOW ADJUSTMENT OF THE DETERGENT SOLUTION").
2. that the squeegee adjustment guarantees a perfect drying result (see under paragraph "ADJUSTMENT OF THE SQUEEGEE").
3. that the brushes pressure permits an efficient washing action in function of the dirt and the speed (see under paragraph "ADJUSTMENT OF THE BRUSHES PRESSURE").

FLOW ADJUSTMENT OF THE DETERGENT SOLUTION

To adjust the detergent solution quantity that flows down onto the brushes it is necessary to act upon the solution valve knob (10) placed on the upper part of the side instrument board, rotating counter-clockwise to increase it and clockwise to reduce it up to closure of the flow.

The side brush has an independent water flow adjustment, with a solution valve (11) placed under the frame near the brush itself.

Please remember that the side brush does not have a scrubbing function but simply moves the dirt towards the center of the machine.

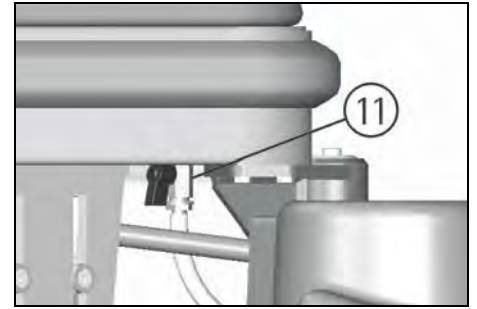
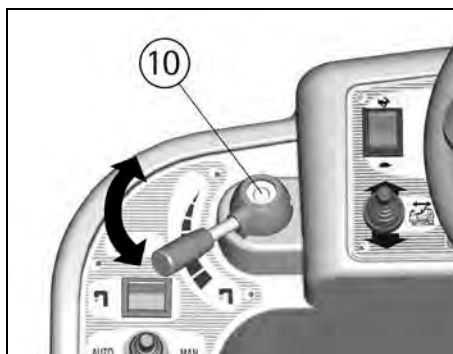

ADJUSTMENT OF THE BRUSHES PRESSURE

Both in automatic as in manual mode it is possible through the selector (4) to adjust the brushes pressure on the floor in eight established levels. During the operation, we can visualize on the display (1) the value in percentage of the electric absorption of the brushes motor by pressing the button (3).

! ATTENTION:

In order not to overload the brushes motor, it is convenient to reduce the brushes pressure going from smooth floors to rough ones (ex. concrete). The presence on the display (1) of a blinking warning from P2 to P8 indicates that the pressure level set determines an overload of the brushes motor. It is therefore necessary to reduce the pressure up to the level where the blinking warning stops.

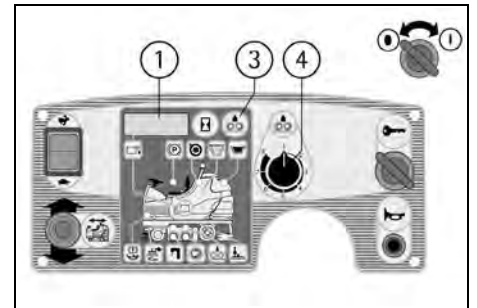

ELECTRIC PROTECTION

The machine is equipped with an electronic system of protection for all components that carry out functions of power or control. This device blocks the defective component and indicates on the display (1) the corresponding alarm from "AL01" to "AL20". The last two figures indicate the number of the alarm code.

! ATTENTION:

To restore the functioning of the component, turn off and on again the machine acting upon the key switch. If the problem persists, please contact the authorized technical assistance.

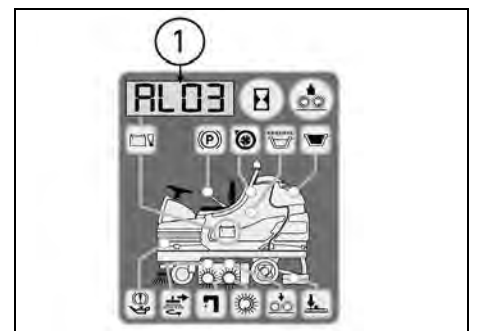

OVERFLOW DEVICE

In order to avoid serious damages to the suction motors, the machine is equipped with a float that intervenes when the recovery tank is full, closing the suc-

tion, the switching on of the signal lamp (20) for the signalling of the full recovery tank and consequently to the drying stop.

When this happens, it is necessary to empty the recovery tank (see under paragraph "RECOVERY TANK EMPTYING AND CLEANING").

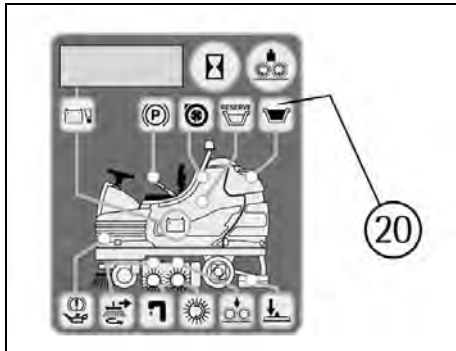

STOP OF THE MACHINE AFTER CLEANING OPERATION

IN AUTOMATIC OR MANUAL WORKING MODE:

1. At the end of the washing cycle put the selector (12) into the central position (BREAK WASHING). In this way automatically the brushes lift, the solenoid valve shuts down and it is possible to finish the drying operation.
2. When the accelerator pedal is released for more than 3 seconds, the squeegee raises itself and the suction switches off automatically.
3. After three seconds, the accelerator can be pressed again, if a machine's transfer has to be made (the transfer can be carried out also if the pedal is never lifted, in this case the squeegee gets lifted and the suction stop automatically after 15 seconds).
4. Turn the switch key counterclockwise to switch off the machine.
5. Insert the parking brake (see under paragraph "EMERGENCY-PARKING BRAKE").

ATTENTION:

The mode (BREAK WASHING) is specific for the transfer at the end of the cleaning operation.

Starting again the cleaning operation:

- A. by positioning to the left the selector (12) into position (AUTO) one can start again to work in an automatic mode.
- B. by positioning to the right the selector (12) into position (MAN) the machine re-establishes the functions pre-set manually.

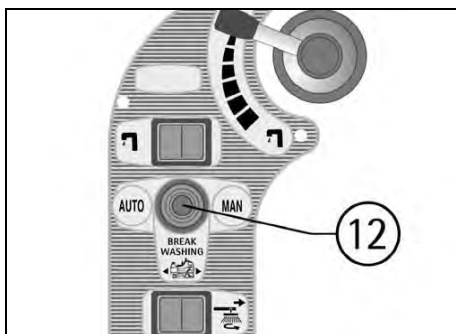

DAILY MAINTENANCE

ATTENTION:

All the maintenance and cleaning operations that refer to the following components that are in contact with liquids and therefore:

- solution and recovery tanks
- collection box
- solution and recovery filters
- squeegee with their rubbers and hoses
- brushes

must be carried out using gloves to protect from contact with dangerous solutions.

RECOVERY TANK EMPTYING AND CLEANING

1. Hold the exhaust hose (1) placed in the rear part of the machine after having taken it off from its fixing support.
2. Take off the plug (2) from the exhaust hose acting upon its lever (3) and empty the recovery tank into appropriate containers, in compliance with the respective rules what the liquid disposal concerns.
3. Unscrew and take off the upper inspection cap (4).
4. Rinse the inside of the tank with a water jet through the inspection hole paying attention to clean also the protection of the float switch placed right under the hole.
5. In case there should be solid waste or encrustation on the bottom of the tank, it is possible to use the lower cleaning door (6). To open it, it is necessary to act upon the lever (7) to release the closing bracket (8).
6. Reassemble all parts.

ATTENTION:

Do not open the lower cleaning door if the recovery tank contains water, check through the upper inspection cap that it is empty.

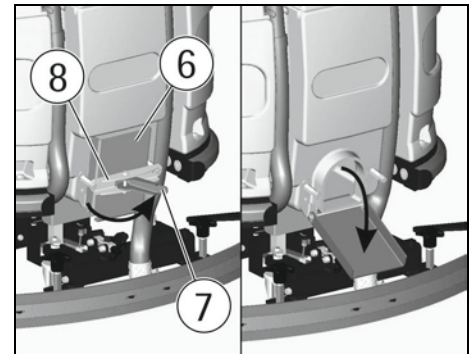
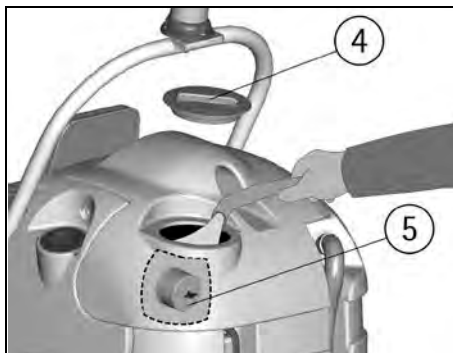
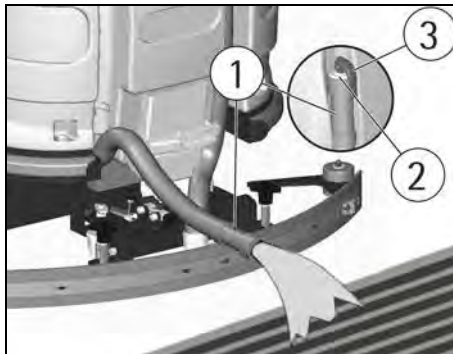

EMPTYING AND CLEANING OF THE COLLECTION BOX

The machine is equipped with a collection box for the solid dirt.

At the end of the cleaning operation it is necessary to empty and to clean it with a water jet.

For the emptying and the cleaning of the box it is convenient to bring the brushes base in working position, then:

1. Position the selector (4) for the adjustment of the brushes pressure on position P1.
2. Activate the machine (see under paragraph "STARTING OF THE MACHINE") positioning the selector (12) to the right to choose the manual mode (MAN).
3. Activate the selector (14) of up/down of the brushes base to lower the brushes.
4. Turn the key counterclockwise to turn off the machine.

ATTENTION:

To carry out above operations with the electric supply on, may cause damages to hands.

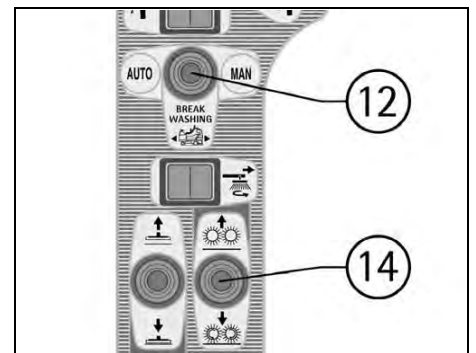
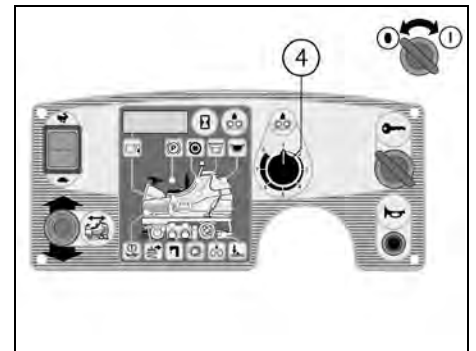

ATTENTION:

This operation must be carried out using gloves to protect from contact with dangerous solutions.

5. Open the bar of the right side rubber after having released it pulling the stop (1) upwards (1).

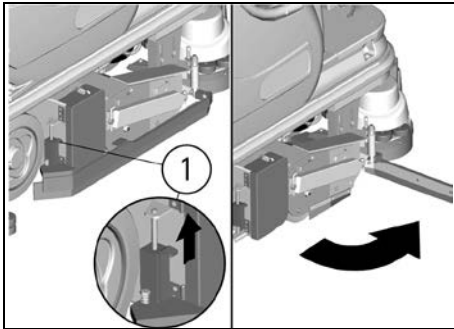

6. Open the door (2).
7. Extract the box holding its handle (3). For its handling, it is convenient to use the two wheels present on the opposite part of the handle.

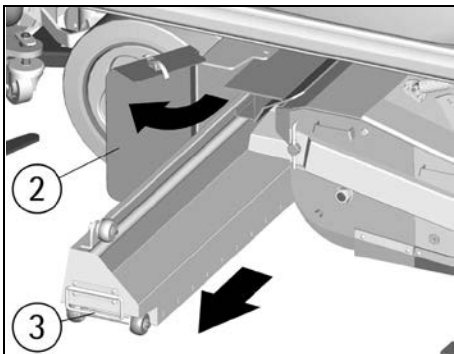

8. Empty the box into appropriate containers, in compliance with the respective rules what the liquid disposal concerns.
9. Put the collection box back into its position paying attention to the correct placing of the sliding rollers.

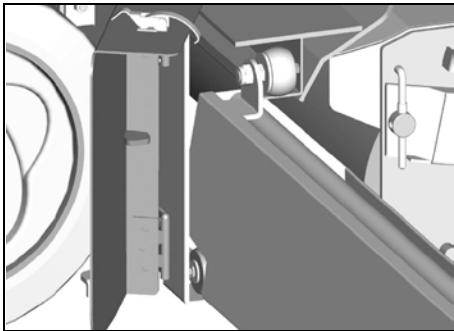

10. Close the door (2) and reposition the bar of the side rubber.

SUCTION FILTER CLEANING

1. Rotate the seat platform forward up to the blocking of the support.
2. Take off the upper hose (1).
3. Unhook the lever closings (2).
4. Take off the plate with the filters (3) and wash it with care.
5. Reassemble all parts.

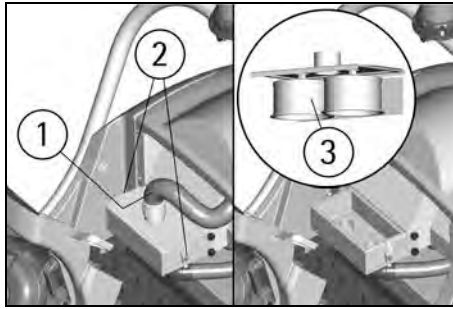

BRUSHES CLEANING

Disassemble the brushes and clean them with a water jet (for the brushes disassembly see under paragraph "BRUSHES ASSEMBLY AND DISASSEMBLY" and "SIDE BRUSH ASSEMBLY AND DISASSEMBLY").



ATTENTION:

To carry out brushes disassembly operations with the electric supply on, may cause damages to hands.

SQUEEGEE CLEANING

Keeping the squeegee clean guarantees always the best drying result.

For its cleaning it is necessary to:

1. Take off the squeegee hose (4) from the coupling.
2. Disassemble the squeegee (2) from its support (1) loosening the stud bolts (3) and making the slide inside the slots up to release them.
3. Clean with care the internal part of the squeegee inlet eliminating eventual dirt residuals.
4. Clean with care the squeegee rubbers.
5. Reassemble all parts.

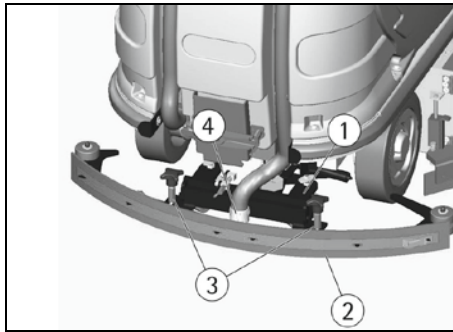

WEEKLY MAINTENANCE

REAR SQUEEGEE RUBBER CHECK

Check the squeegee rubber wear and eventually turn or replace it.

For the replacement it is necessary to:

1. Take off the squeegee (see under paragraph "SQUEEGEE CLEANING").
2. Unscrew the screws (1) that block the rubber blade and take off the rubber.
3. Turn the rubber to a new side or replace it.

To reassemble the squeegee repeat inversely above-mentioned operations, inserting the rubber on the guides and blocking it with the rubber holder blade.

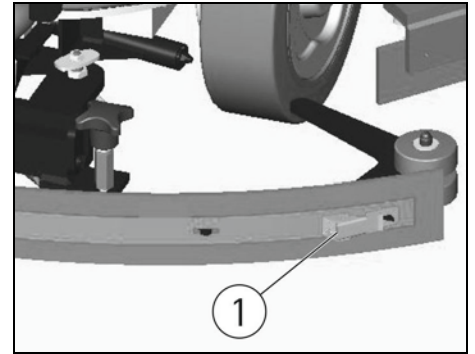

CHECK OF THE SIDE RUBBERS

With the brushes assembled, the side rubbers must touch the floor. If they are worn, they have to be replaced.

To replace the rubbers:

1. Open the bars of the right and left side rubber after having released them by pulling the stops (1) upwards.
2. Take off the fixing screws (2) of the inner rubber blades and replace the rubber.
4. Reassemble all parts.

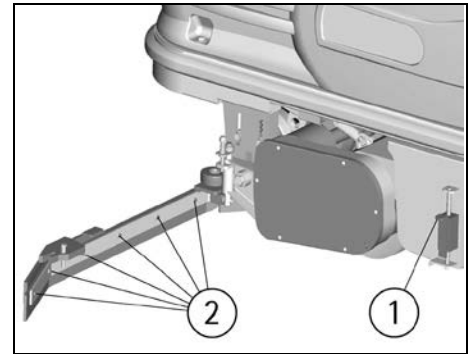

SQUEEGEE HOSE CLEANING

Weekly or in case of insufficient suction, it is necessary to check that the squeegee hose is not obstructed. Eventually, to clean it, proceed as follows:

1. Take off the hose (1) from the squeegee coupling.
2. Wash the inside of the hose with a water jet.
3. To reassemble the hose repeat inversely the above-mentioned operations.

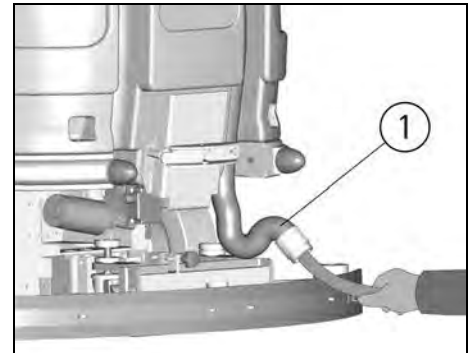

CLEANING OF THE SOLUTION TANK AND OF THE OUTER FILTER

1. Bring the machine to an appropriate place for the detergent solution draining.
2. Unscrew the solution tank cap (1).
3. Unscrew the cap of the exhaust filter (2) and take off the filter. Be careful not to lose the gasket of the cap.
4. Open the solution valve adjustment (see under paragraph "FLOW ADJUSTMENT OF THE DETERGENT SOLUTION"), so that the detergent solution flows down into appropriate containers.

- Rinse with a water jet the solution tank and the components of the filter.
- Reassemble all parts.

NOTE: in case of need it is possible to wash only the components of the outer solution filter as above-mentioned by closing the solution valve adjustment (see under paragraph "FLOW ADJUSTMENT OF THE DETERGENT SOLUTION"), so that the detergent solution remains in the solution tank.

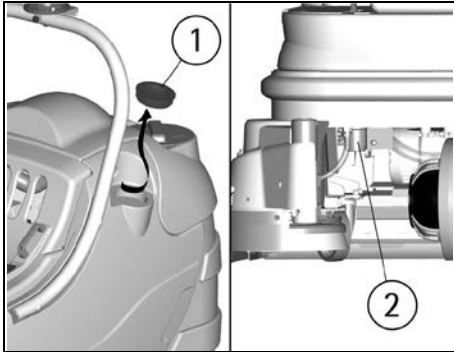

TWO-MONTHLY MAINTENANCE

FRONT SQUEEGEE RUBBER CHECK

Check the wear of the squeegee rubber and eventually replace it.

For the replacement it is necessary to:

- Take off the squeegee (see under paragraph "SQUEEGEE CLEANING").
- Unscrew the wing nuts in the front part of the squeegee.
- Take off the rubber holder blade.
- Replace the front rubber.
- Reassemble all parts.

SIX-MONTHLY MAINTENANCE

SPLASH GUARD RUBBER CHECK OF THE SIDE BRUSH

With the brush assembled, the splash guard of the side brush must slightly touch the floor. If the rubber is worn, it has to be replaced.

The device has to be in rest position at machine stop.



ATTENTION:

To carry out above operations with the electric supply on, may cause damages to hands.

To replace the rubber:

- Take off the side brush (see under paragraph "SIDE BRUSH ASSEMBLY AND DISASSEMBLY").
- Take off the screws (1) that block the rubber blade and replace the rubber.
- Reassemble all parts.

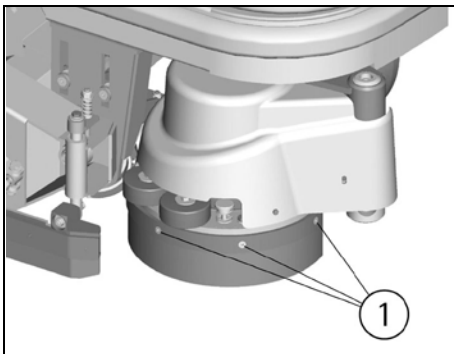

CHECK OF THE BRAKES

Check the braking efficacy of both rear wheels. Should the braking be insufficient, please contact the authorized technical assistance.

TROUBLESHOOTING GUIDE

NOTE: The machine is equipped with a control system of the main functions with indication on the display of a probable malfunction with codified alarms: AL 01, AL 02, etc. The alarm 20 is general and foresees and additional check of the quantity of blinkings to be read on the led placed on the chopper card.



ATTENTION:

If with the key switch positioned clockwise to switch on the machine the display and other functions are not activated, it is necessary to check the batteries' connection to the machine (see under paragraph "CONNECTION BATTERIES' CONNECTION AND SWITCHING ON OF THE MACHINE"). If the problem persists, please contact the authorized technical assistance.

THE SUCTION MOTOR DOES NOT WORK

- Verify that the key switch (5) is positioned clockwise to switch on the machine. In presence of alarm signals it is necessary to switch off and on again the machine to restore the functionality.
 - Check the charge level of the batteries on the display (1).
 - Verify of having activated correctly the function of drying (see under paragraph "STARTING OF THE MACHINE").
 - If, both in mode (MAN) as (AUTO), the signal lamp (18) is on but the suction system does not work, it is necessary to check the connection of the suction motor plugs situated in the compartment behind the seat.
 - The that the recovery tank is not full.
 - Check that the float switch (2) in the recovery tank is assembled correctly.
- If the problem persists, please contact the authorized technical assistance.

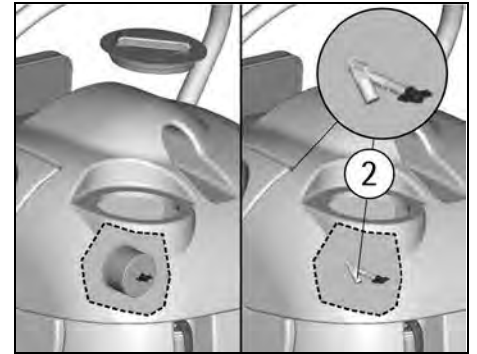
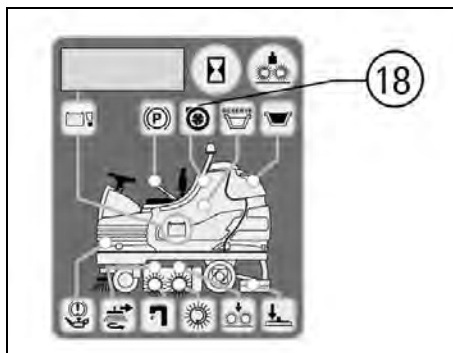
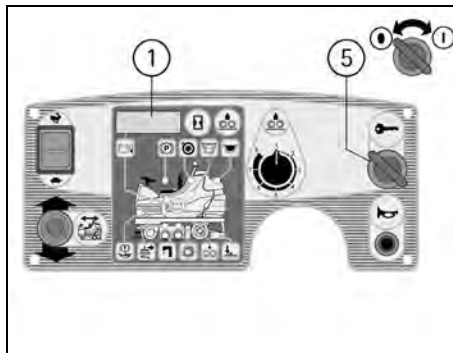

THE BRUSHES MOTOR DOES NOT WORK

- Verify that the key switch (5) is positioned clockwise to switch on the machine. In presence of alarm signals it is necessary to switch off and on again the machine to restore the functionality.
 - Check the charge level of the batteries on the display (1).
 - Verify of having activated correctly the function of washing with the brushes (see under paragraph "STARTING OF THE MACHINE").
 - If, both in mode (MAN) as (AUTO), the signal lamp (23) is on but the brushes do not turn, please contact the authorized technical assistance.
- If the problem persists, please contact the authorized technical assistance.

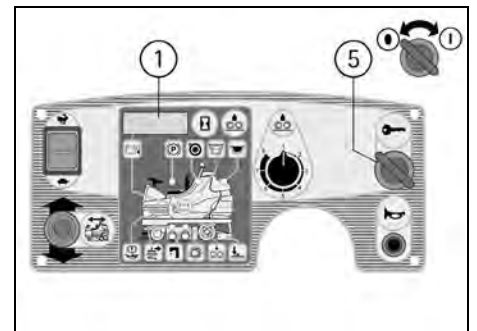

THE TRACTION MOTOR DOES NOT WORK

- Sit on the guiding place.
 - Verify that the key switch (5) is positioned clockwise to switch on the machine. In presence of alarm signals it is necessary to switch off and on again the machine to restore the functionality.
 - Check the charge level of the batteries on the display (1).
 - Check through the signal lamp (17) that the parking brake is not inserted and eventually release it (see under paragraph "EMERGENCY-PARKING BRAKE").
 - Check that the selector (8) is in the movement position.
 - Press the accelerator pedal placed on the right side to start the machine.
- If the problem persists, please contact the authorized technical assistance.

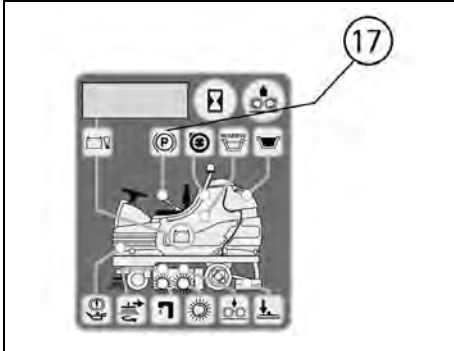
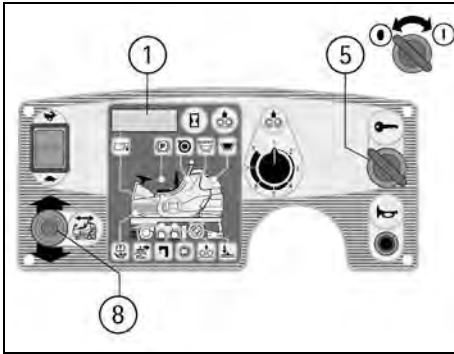

THE WATER DOES NOT COME DOWN ONTO THE BRUSHES OR IS INSUFFICIENT

1. Verify that the key switch (5) is positioned clockwise to switch on the machine.
2. Check the charge level of the batteries on the display (1).
3. Verify of having activated correctly the function of washing with the brushes (see under paragraph "STARTING OF THE MACHINE").
4. Check that the solution valve is open (see under paragraph "FLOW ADJUSTMENT OF THE DETERGENT SOLUTION").
5. If, both in mode (MAN) as (AUTO), the signal lamp (24) is on but the detergent solution does not come down onto the brushes, it is necessary to:
 - a. check the level of the liquid in the tank.
 - b. check that the solution filter is clean (see under paragraph "CLEANING OF THE SOLUTION TANK AND OF THE OUTER FILTER").

If the problem persists, please contact the authorized technical assistance.

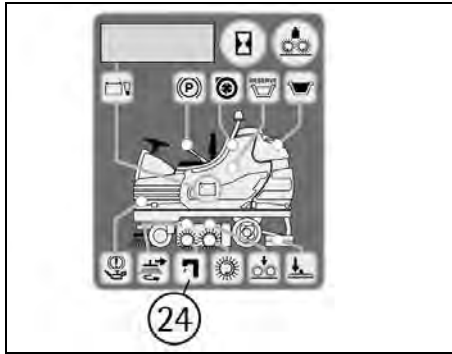
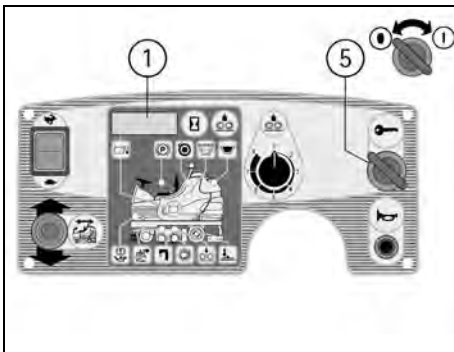

THE MACHINE DOES NOT CLEAN PROPERLY

1. The brushes do not have the suitable bristle dimension: contact the authorized technical assistance.
2. The brushes have got worn bristles. Check the brushes wear condition and eventually replace them. To replace the brushes, see instructions under paragraph "BRUSHES DISASSEMBLY" and "BRUSHES ASSEMBLY".
3. The detergent solution is insufficient: open more the solution valve (see under paragraph "FLOW ADJUSTMENT OF THE DETERGENT SOLUTION").
4. Check that the liquid detergent is in the recommended percentage.
5. Increase the brushes base pressure (see under paragraph "ADJUSTMENT OF THE BRUSHES PRESSURE").

Contact the authorized technical assistance for advice.

THE SQUEEGEE DOES NOT DRY PERFECTLY

1. Check that the suction function is on and that the recovery tank is not full.
2. Check that the squeegee rubbers are clean (see under paragraph "SQUEEGEE CLEANING").
3. Check the adjustment of the height and the inclination of the squeegee (see under paragraph "ADJUSTMENT OF THE SQUEEGEE").
4. Check that the suction and the squeegee hoses are correctly inserted in their proper seats on the recovery tank.
5. Clean the suction filter (see under paragraph "SUCTION FILTER CLEANING").
6. Clean the squeegee hose (see under paragraph "SQUEEGEE HOSE CLEANING").
7. Replace the rubbers if worn out.

Contact the authorized technical assistance for advice.

EXCESSIVE FOAM PRODUCTION

Check that low foam detergent has been used. Eventually add small quantities of anti foam liquid into the recovery tank.

Please be aware that a bigger quantity of foam is produced when the floor is not very dirty. In this case please dilute detergent solution.

PROGRAMMED MAINTENANCE

INTERVENTION	DAILY	20 HOURS *	200 HOURS *	1000 HOURS *
RECOVERY TANK CLEANING	•			
SUCTION FILTER CLEANING	•			
SOLUTION TANK FILTER CLEANING		•		
BRUSHES CLEANING	•			
BRUSHES DISASSEMBLY AND CLEANING	•			
SQUEEGEE CLEANING	•			
FRONT SQUEEGEE RUBBER REPLACEMENT			•	
REAR SQUEEGEE RUBBER REPLACEMENT		•		
REPLACEMENT SIDE RUBBERS			•	
REPLACEMENT SPLASH GUARD SIDE BRUSH				•
CHECK SQUEEGEE ADJUSTMENT		•		
SQUEEGEE HOSE CLEANING		•		
SOLUTION TANK CLEANING		•		
CHECK BATTERIES ELECTROLYTE		•		
CHECK OF THE BRAKES				•
TRACTION MOTOR CHECK				•
BRUSHES MOTOR CHECK				•
SUCTION MOTORS CHECK			•	
CHECK BRUSHES BASE GROUPS			•	
SCREW TIGHTENING				•

* The hours refer to the ones indicated on the display (see under paragraph "HOUR METER").

RECOMMENDED BRUSHES

Brushes must be chosen depending on type of floor and dirt to be removed.

The employed material and the bristles diameter are the elements that distinguish different types of brushes.

MATERIAL	CHARACTERISTICS
PPL (Polypropylene)	Good wear resistance. Maintains characteristics with hot water up to 60°C. It is not hygroscopic.
NYLON	Excellent wear resistance, even with hot water over 60°C. It is hygroscopic. It loses its physical characteristics over the time.
TYNEX	Nylon bristles with grains of abrasive material. Use with caution in order not to mark the floor or ruin the polishing.
BRISTLES THICKNESS	Thicker bristles are more rigid and must be used on smooth floor or floor with small joints. On irregular floors with deep joints or relieves, it is recommended to use softer bristles which penetrate more easily and deeper. Please be aware that when brush bristles are worn out and therefore too small, they become rigid and unable to penetrate and clean deeper. This may also happen with thicker bristles creating brush vibration.

MACHINE	CODE	QUANTITY	DESCRIPTION	USE
diamond 100s	48907050	1	Cylindrical brush PPL 0,5 Ø 150	Smooth floors with small joints and persistent dirt.
	48907060	1	Cylindrical brush PPL 1 Ø 280	Smooth floors with small joints and persistent dirt.
	48907070	1	Cylindrical brush NYLON 0,8 Ø 150	Floors of resistant material and particularly dirty.
	48907080	1	Cylindrical brush TYNEX Ø 280	Floors of resistant material and particularly dirty.
	48907090	1	Cylindrical brush TYNEX LIGHT Ø 280	Floors of resistant material and particularly dirty.
	48907100	1	Side brush PPL 0,9 Ø 285	For all types of floors.

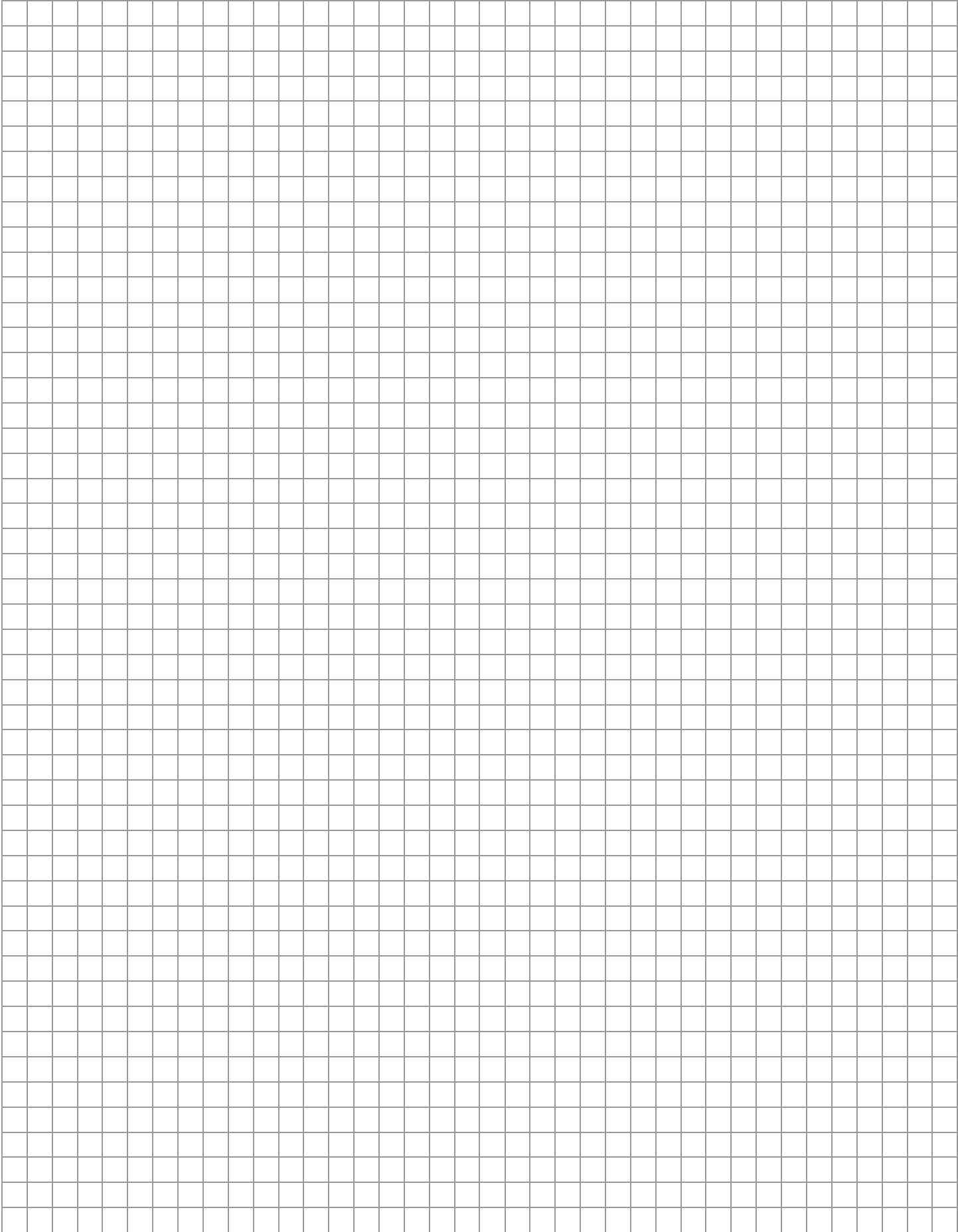



ADIATEK® Takarítógépek Magyarországi Képviselője

H-9700 Szombathely, Zanati út 26. Fsz. – Zanati 26 Irodaház

Telefon: +36 94 452 972, +36 70 409 2655

E-mail: info@takaritogepcentrum.hu

www.takaritogepcentrum.hu